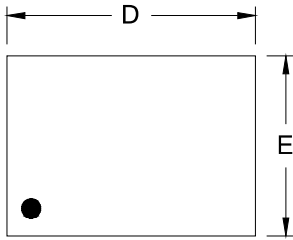
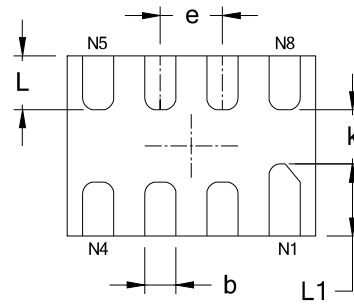
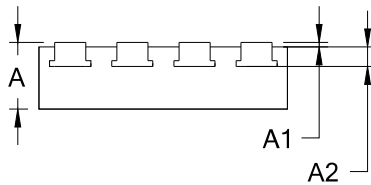
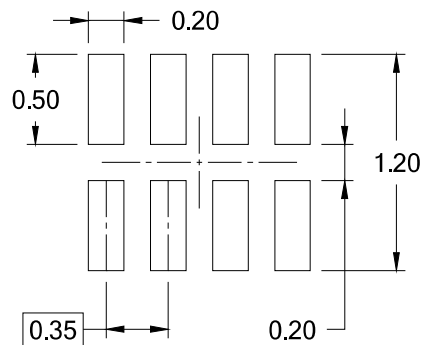

**DFN1.4x1.0-8L<sup>(3)</sup>**

**TOP VIEW**

**BOTTOM VIEW**

**SIDE VIEW**

**RECOMMENDED LAND PATTERN (Unit: mm)**

Symbol	Dimensions In Millimeters		Dimensions In Inches	
	Min	Max	Min	Max
A <sup>(1)</sup>	0.340	0.400	0.013	0.016
A1	0.000	0.050	0.000	0.002
A2	0.110 REF <sup>(2)</sup>		0.004 REF <sup>(2)</sup>	
D <sup>(1)</sup>	1.350	1.450	0.053	0.057
E <sup>(1)</sup>	0.950	1.050	0.037	0.041
k	0.200 MIN		0.008 MIN	
b	0.150	0.200	0.006	0.008
e	0.350 TYP		0.014 TYP	
L	0.250	0.350	0.010	0.014
L1	0.350	0.450	0.014	0.018

**NOTE:**

1. Plastic or metal protrusions of 0.075mm maximum per side are not included.
2. REF is the abbreviation for Reference.
3. This drawing is subject to change without notice.