

WPFxxAxK

Series (Rev: M)

Surface-mount devices

1. Features

- Halogen free;
- SMD Electronic devices;
- High structural intensity;
- Over current protection ;
- Over charge protection;
- Compatible with reflow soldering processes
- UL: UL-248-1,UL-248-14····File Number: E311435
- TUV: EN60127-1,EN60127-4····File Number:J50552619

**2. Environmental Characteristics**

(1) Contents of halogens used in each material for the product are as follows.

Halogen substance	Content
Chlorine (CL)	≤ 900ppm (0.09%)
Bromine (Br)	≤ 900ppm (0.09%)
Total concentration of chlorine (Cl) + bromine (Br)	≤ 1500ppm (0.15%)

(2) The product described in this specification complies with the RoHS Directive. BOM table contains the high-temperature alloy, solder, some electronic slurry, including lead, but are in line with the relevant provisions of the ROHS directive.

Specifications are subject to change without notice

3. Dimensions and Circuit Chart

3.1 Dimensions

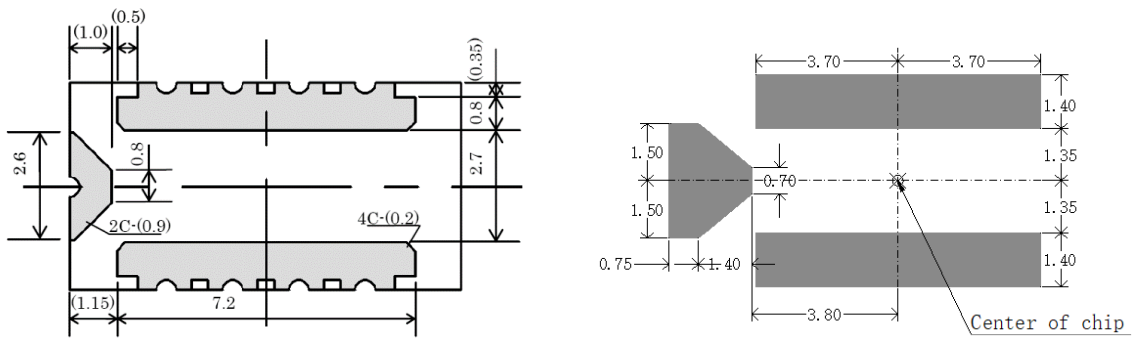
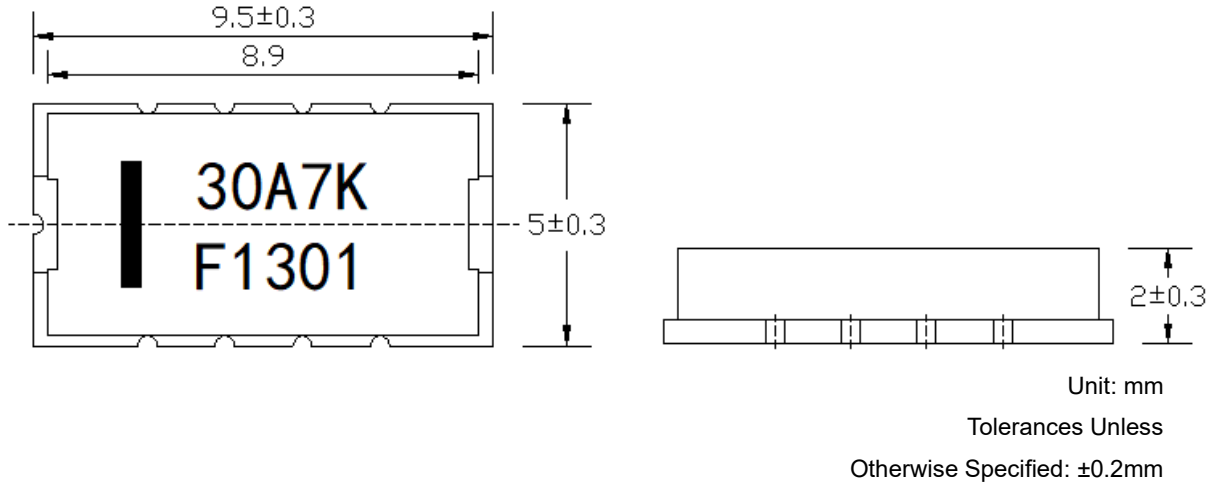

3.2 Construction

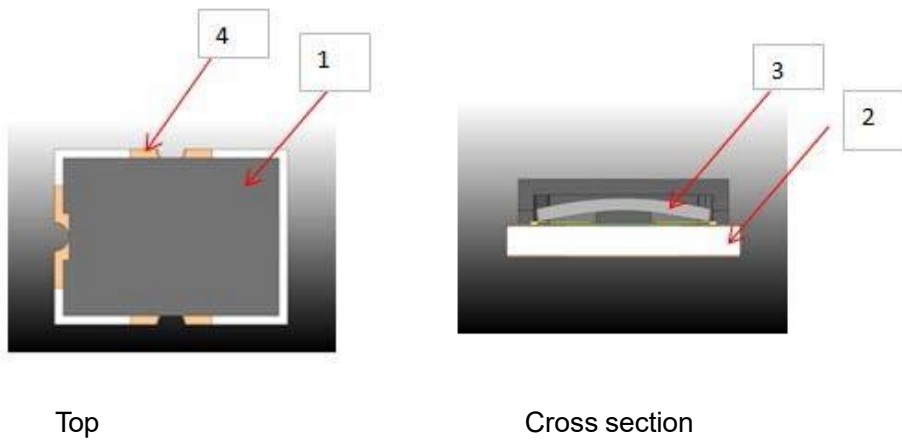

Note: The top cover of the product shown in the figure does not distinguish between the right and the left.

No.	Name	Material
1	Cap	LCP
2	Ceramic	Al ₂ O ₃
3	Alloy	Sn/Pb/Ag
4	Termination electrode	Ag/Pd/Ni/Au

Specifications are subject to change without notice

3.3 Circuit Chart

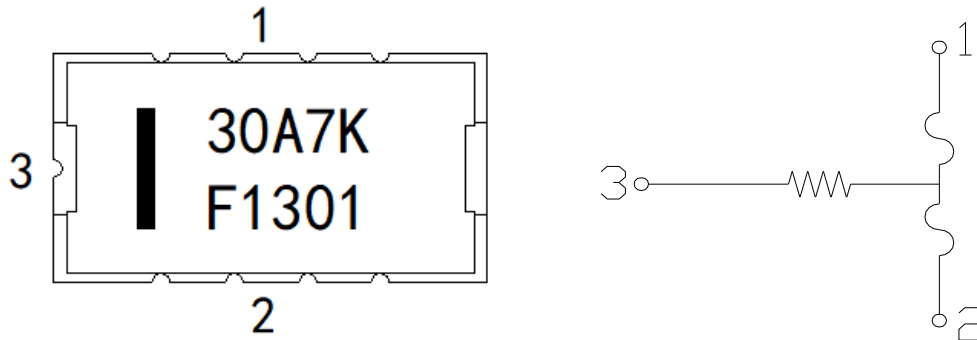

4. Marking requirements

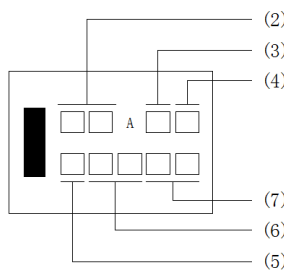
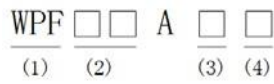

- (1) WPF: SCF/Way-on SCF protector;
- (2) Rated current: 30A,45A,60A;
- (3) Commercial Code;
- (4) Length width size code;K:9.5×5.0mm;
- (5) Year: I: 2023; J: 2024; K: 2025;.....;
- (6) Week of year: 01、02.....52;
- (7) Running number: 01、02.....

Specifications are subject to change without notice

5. Electrical Characteristics

Part Number	Current Rating	Voltage Rating ★	Operating Voltage	Fuse DCR (1)	Heater DCR (2)	Interrupting Rating	Applicable Cells in series
	A	VDC	V	mΩ	Ω	A	cell
WPF30A1K	30	62	4.0-6.6	1.0-2.5	0.8-1.2	80	1
WPF30A2K	30	62	5.6-9.0	1.0-2.5	0.7-2.4	80	2
WPF30A3K	30	62	8.4-19.1	1.0-2.5	3.2-5.2	80	3
WPF30A4K	30	62	10.5-23.5	1.0-2.5	4.8-8.0	80	4~5
WPF30A5K	30	62	15.0-23.5	1.0-2.5	4.8-17.2	80	5
WPF30A7K	30	62	20.2-31.5	1.0-2.5	18.8-31.2	80	6-7
WPF30A7K-2	30	80	26.4-36.0	1.0-2.5	24.0-52.0	80	8
WPF30A9K	30	80	20.2-46.3	1.0-2.5	18.8-31.2	80	6~9
WPF30A14K	30	80	28.0-62.0	1.0-2.5	40.0-60.0	80	10~14
WPF30A14K-3	30	80	39.6-72.0	1.0-2.5	59.0-120.0	80	15~17
WPF30A14K-7	30	80	70.0-90.0	1.0-2.5	72.0-145.0	80	20
WPF30A14K-11	30	120	72.0-120.0	1.0-2.5	264.0-396.0	80	22-27
WPF30A14K-23	30	120	90-133.2	1.0-2.5	200.0-333.3	80	36
WPF30A9K-2P	30	80	35.0-51.8	1.0-2.5	10.0-20.0	80	8 LFP
WPF30A14K-P	30	80	50.0-51.8	1.0-2.5	36.0-60.0	80	14 LFP
WPF30A14K-2P	30	80	37.5-55.5	1.0-2.5	42.0-70.0	80	15 LFP
WPF30A14K-3P	30	80	36.0-62.0	1.0-2.5	42.0-70.0	80	16 LFP
WPF30A14K-4P	30	80	42.5-62.9	1.0-2.5	54.0-90.0	80	17 LFP
WPF30A14K-7P	30	80	50.0-74.0	1.0-2.5	60.0-100.0	80	20 LFP
WPF30A14K-11P	30	120	66.0-92.0	1.0-2.5	105-175.0	80	24 LFP
WPF45A2K	45	80	7.0-9.2	0.5-1.5	0.85-1.48	120	2
WPF45A3K	45	80	9.8-13.5	0.5-1.5	1.9-2.9	120	3
WPF45A4K	45	80	13.0-18.4	0.5-1.5	3.4-5.1	120	4
WPF45A5K	45	80	16.7-23.5	0.5-1.5	5.6-8.4	120	5
WPF45A5K-2	45	80	19.8-27.0	0.5-1.5	7.4-11.8	120	6
WPF45A7K	45	80	22.3-31.5	0.5-1.5	10.0-15.0	120	6~7
WPF45A8K	45	80	26.7-37.6	0.5-1.5	14.4-21.5	120	8
WPF45A10K	45	80	33.0-47.0	0.5-1.5	22.0-33.0	120	9~10
WPF45A14K	45	120	43.7-62.0	0.5-1.5	38.5-57.8	120	12~14
WPF45A14K-2	45	120	52.5-67.5	0.5-1.5	46.0-83.0	120	15
WPF45A14K-6	45	120	56.0-70.4	0.5-1.5	55.0-95.0	120	16
WPF45A14K-4	45	120	51.0-76.5	0.5-1.5	64.0-104.0	120	17
WPF45A14K-7	45	120	70.0-90.0	0.5-1.5	72.0-145.0	120	20
WPF45A14K-11	45	120	84.0-108.0	0.5-1.5	117.0-210.0	120	24
WPF45A9K-2P	45	80	20.0-30.0	0.5-1.5	8.0-12.0	120	8 LFP
WPF45A14K-P	45	80	36.4-51.8	0.5-1.5	27.0-41.0	120	14 LFP
WPF45A14K-2P	45	80	40.0-54.0	0.5-1.5	29.2-48.4	120	15 LFP
WPF45A14K-3P	45	80	36.0-62.0	0.5-1.5	46.8-78.0	120	16 LFP
WPF45A14K-4P	45	80	44.2-62.9	0.5-1.5	39.6-59.2	120	17 LFP
WPF45A14K-7P	45	80	50.0-74.0	0.5-1.5	55.0-75.5	120	20 LFP
WPF45A14K-JP	45	120	60.0-85.0	0.5-1.5	72.5-109.0	120	23 LFP
WPF45A14K-11P	45	120	72.0-92.0	0.5-1.5	85.0-156.5	120	24 LFP

Specifications are subject to change without notice

WPF60A3K	60	80	9.6-13.5	0.5-1.5	1.83-2.75	160	3
WPF60A4K	60	80	13.0-18.4	0.5-1.5	3.4-5.1	160	4
WPF60A5K	60	80	16.7-23.5	0.5-1.5	5.6-8.4	160	5
WPF60A7K	60	80	22.3-31.5	0.5-1.5	10.0-15.0	160	6~7
WPF60A8K	60	80	26.7-37.6	0.5-1.5	14.2-21.3	160	8
WPF60A10K	60	80	33.0-49.6	0.5-1.5	22.0-33.0	160	9~10
WPF60A14K	60	80	43.7-62.0	0.5-1.5	38.5-57.76	160	12~14
WPF60A14K-2	60	80	52.5-67.5	0.5-1.5	46.0-83.0	160	15
WPF60A14K-3	60	80	56.0-72.0	0.5-1.5	52.0-95.0	160	16
WPF60A14K-4	60	80	59.5-76.0	0.5-1.5	70.0-105.0	160	17
WPF60A14K-7	60	120	42.0-90.0	0.5-1.5	81.0-121.5	160	20
WPF60A14K-2P	60	80	40.0-54.0	0.5-1.5	29.2-48.4	160	15 LFP
WPF60A14K-3P	60	80	36.0-62.0	0.5-1.5	46.8-78.0	160	16 LFP
WPF60A14K-23	60	150	90.0-133.2	0.5-1.5	160.0-240.0	160	36 LFP

★Rated voltage is the maximum voltage that the fuse can block, not the action voltage of the heater assembly.

6. Clear-Time Characteristics

Test Item	Condition of Test	requirement at 25℃
Carrying Capacity (UL248-14)	100% of rated current, 4hr	No Melting
Fusing Time (UL248-14)	200% rated Current	≤1min
	In operation voltage range	

Operating temperature range: -10~65℃ (Fusing time≤1min)

Electrical Characteristics is influenced by thermal capacity of PCB, parts, pattern width, and so on. Therefore you should check it on your PCB.

7. Standard test condition

In the absence of additional test environmental standards, the test environmental standards are as follows;

Ambient temperature: 5 to 35℃;

Relative humidity: 45 to 85%RH; Air

pressure: 86 to 106kPa.

If you have any questions about the test results, please follow the following environmental standards;

Ambient temperature: 20±2℃;

Relative humidity: 60 to 70%RH; Air

pressure: 86 to 106kPa.

Specifications are subject to change without notice

8. Reliability

Test Item	Project	Condition	Requirements
Electrical performance	Over voltage	Operating voltage shall be applied to heater	Fusing Time \leq 1min
	Insulation	@100VDC after OV operating voltage test	$>0.2M\Omega$
	Withstand voltage	@100VAC @50-60Hz@60s after OV operating voltage test	No breakdown
	Over current	200% of Rated current	Fusing Time \leq 1min
	Carrying Capacity	100% of rated current, 4hr	No Melting
Reliability performance	High temperature	100°C \pm 5°C@250hr	Without deformation of case or excessive looseness of caps. Electrical characteristics shall be satisfied.
	High humidity	60°C \pm 2°C@90%~95%@250hr	
	Keeping cold	-20°C \pm 3°C @ 500hr	
	Pulse	5 \times In (In = rated current) A @ 25°C @on 5ms/off 995 ms, 100,000 cycles	No operating;
Mounting Characteristics	Solder ability	Solder: Pb-free (Sn96.5/Ag3/Cu0.5[%]) Flux: 25wt%Rosin Ethanol solution Dipping depth: 2~2.5mm Temperature: 245 \pm 5°C Dipping time: 3 \pm 0.5s Dipping and drawing speed: 25 \pm 2.5mm/s	A new uniform coating of solder shall cover a minimum of 95% of the surface being immersed.
	Resistance to soldering heat	① Reflow soldering method Peak temp: 255°C \pm 5°C 5s 230°C \pm 5°C 30s At electrode temperature of the specimen.(Solder temperature) The specimen shall be passed through the reflow furnace with the condition shown in the above profile for 2times. The specimen shall be stored at standard atmospheric conditions for 24h after which the measurement shall be made. ② Soldering iron method Bit temperature: 300 \pm 5°C Application of soldering iron: 3 \pm 1s Apply the soldering iron to the electrode. The specimen shall be stored at standard atmospheric condition for 24h, after which the measurements shall be made	Without deformation of case or excessive looseness of caps. Electrical characteristics shall be satisfied.

Electrical Characteristics is influenced by thermal capacity of PCB, parts, pattern width, and so on. Therefore you should check it on your PCB.

Specifications are subject to change without notice

9. Recommended Solder Pad Dimensions

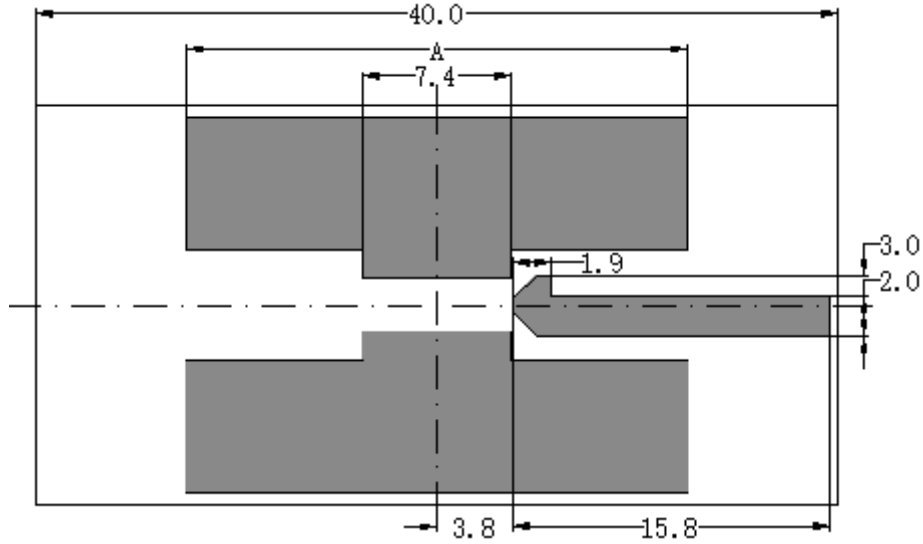

Unit: mm

Type	Materials	Copper width A	Base thickness	Copper thickness	Covered wires
30A	FR-4	6mm	0.6 mm	2.0OZ	AWG10
45A	FR-4	25mm	0.6 mm	3.0OZ	AWG8
60A	FR-4	25mm	0.6 mm	3.0OZ	AWG8

When the patch on the PCB board printed solder paste steel mesh thickness is best not more than 0.12 mm.

10. Solder Reflow Recommendations

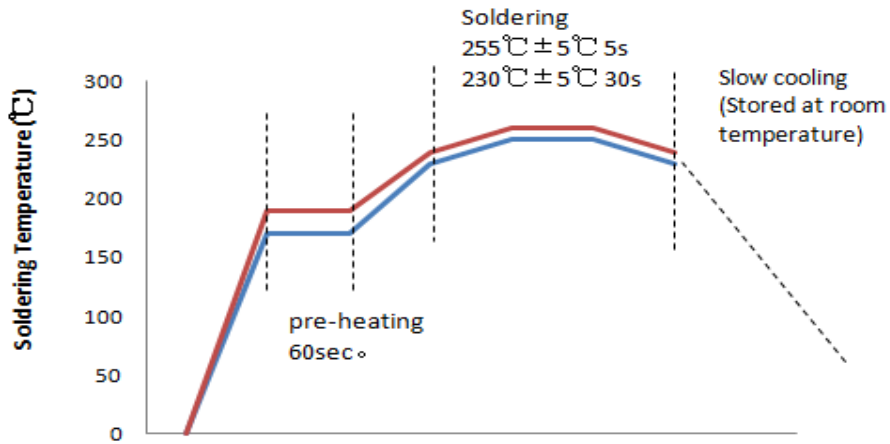

Reflow soldering method:

Peak temp: 255°C±5°C 5s, 230°C±5°C 30s. The specimen shall be passed through the reflow furnace for 2times.

Specifications are subject to change without notice

11. Packaging Data

Package form is embossed tape packing.

11.1 Dimension of Tape and Reels

Code	(mm)
E	1.05±0.10
F	7.50±0.10
P2	2.00±0.10
D	1.50+0.1/-0
D1	1.50+0.1/-0
P0	4.00±0.10
10P0	40.0±0.20
W	16.00±0.30
P	8.00±0.10
A0	5.3±0.10
B0	9.8±0.10
K0	2.3±0.10
t	0.30±0.05

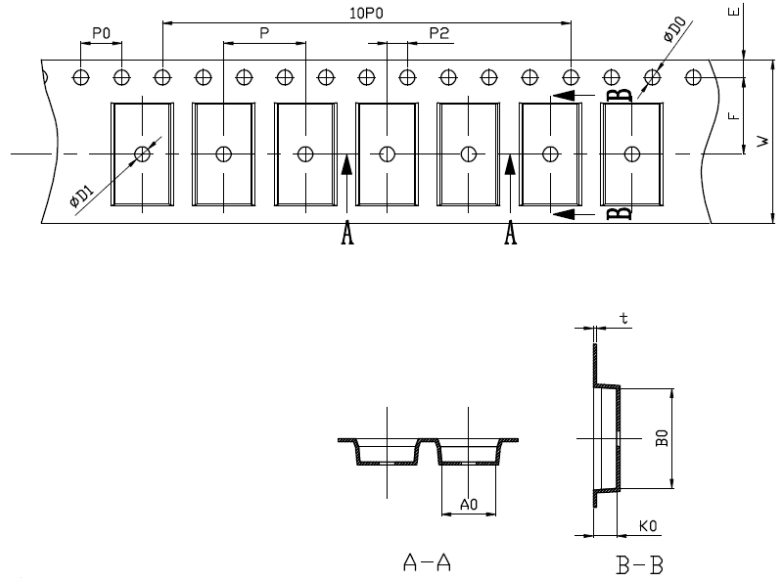

Code	(mm)
A	330±1.0
B	2+0.5/-0
C	13±0.2
D	21±0.2
W	22.7±0.5

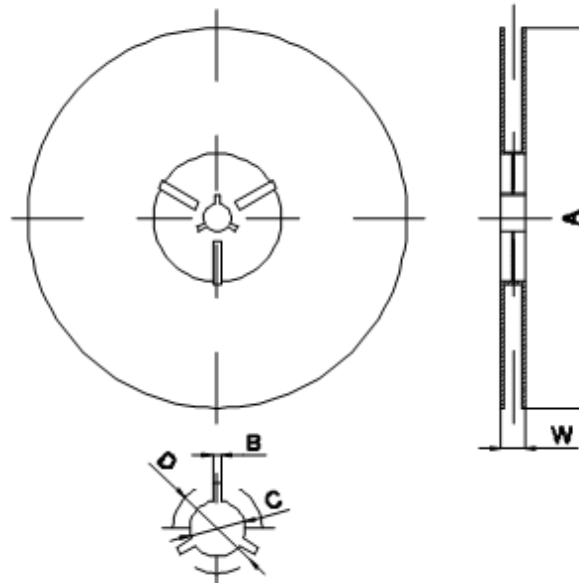

11.2 Packing Quantity

3000pcs /reel.

Specifications are subject to change without notice

11.3 Direction of Taping

The direction shall be seen from the top cover tape side.

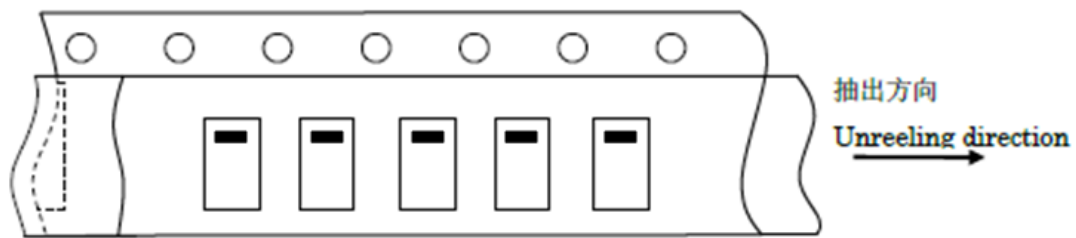

11.4 Label (example)

The label contains the following content:

- (1) manufacturer of trademark and factory address,
- (2) product type,
- (3) product batch number,
- (4) quantity,
- (5) shipment inspection personnel quality code,
- (6) date of shipment,
- (7) the certification mark.

Specifications are subject to change without notice

12. Storage

The product must be stored in carton or plastic bag, in the conditions of ambient temperature of -10°C to 40°C, RH of less than 60%, no radical temperature change, no direct sunshine, excessive vibration and shock.

The preservation period when it is kept on the above condition is 1 year.

Should avoid to store at where there is possibility of generating corrosive gas, such as salt mist, chlorine, hydrogen sulfide, ammonium, sulfide-oxidation, hydrogen chloride, etc.

13. Cautions for using

(1) Can predict, the heat capacity of the test board current carrying capacity of a heater to work with the use of the relevant characteristics, therefore, before use to check the test board PCB you use, generally PCB plate heat capacity is bigger, the longer the action.

(2) The data referred to in this specification are tested under the PCB standard of UL(0.6t Glass Epoxy single-sided copper laminated), The characteristics influenced thermal capacity of PCB, on the machine before using the PCB to do the actual test to confirm the by.

(3) Ultrasonic-cleaning or immersion-cleaning and so on must not be done to SCF before and after mounted. When cleaning is done, flux on element would flow, and it would not be satisfied its specification. Moreover, a similar influence happens when the product comes in contact with cleaning-solution. These products after cleaning will not be guaranteed..

(4) This product can not be used in resin packaging, packaging process of resin into the product, resulting in poor product performance.

(5) Please do not re-use of the product removed by the solder correction.

(6) Please confirm the connection with the three terminal circuit board , where in 1-2, 2-3 is used as a heating end with high resistance.

(7) This product is designed and used in conventional electronic devices, so we do not recommend the use of military, medical and other areas of other people and property may cause direct damage.

(8) If there is any doubt or change in the contents of this book, please inform us in advance so that both parties can reach an agreement.

Specifications are subject to change without notice