

### Features

- Way-on Small Signal MOSFETs
- $V_{DS} = 30V$ ,  $I_D = 0.6A$   
 $R_{DS(on)} < 0.50\Omega @ V_{GS} = 4.5V$   
 $R_{DS(on)} < 0.68\Omega @ V_{GS} = 2.5V$
- Trench LV MOSFET Technology
- ESD Protected

### Mechanical Characteristics

- SOT-23 Package
- Marking : Making Code
- RoHS Compliant

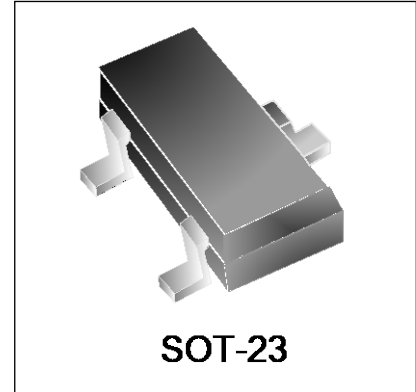

### Schematic & PIN Configuration

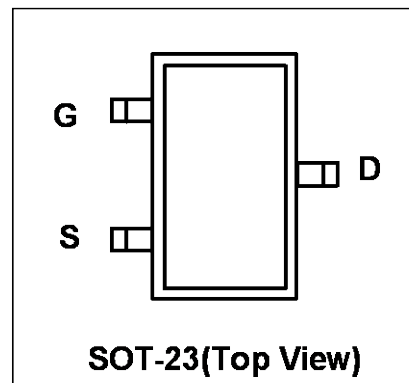
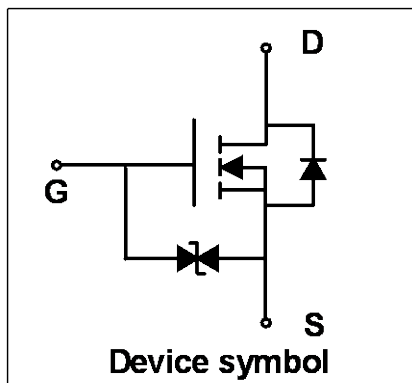

### Absolute Maximum Rating ( $T_A=25^\circ C$ unless otherwise noted)

Parameter	Symbol	Value	Unit
Drain-Source Voltage	$V_{DS}$	30	V
Gate-Source Voltage	$V_{GS}$	$\pm 12$	V
Continuous Drain Current	$I_D$	0.6	A
Pulsed Drain Current <sup>1</sup>	$I_{DM}$	2.4	A
Power Dissipation	$P_D$	0.35	W
Operating Junction and Storage Temperature Range	$T_J, T_{STG}$	-55 to +150	$^\circ C$

### Thermal Characteristics

Parameter	Symbol	Value	Unit
Thermal Resistance from Junction to Ambient <sup>2</sup>	$R_{\theta JA}$	357	$^\circ C/W$

**Electrical Characteristics (T<sub>J</sub>=25°C unless otherwise noted)**

Parameter	Symbol	Test Condition	Min.	Typ.	Max.	Unit
<b>Static Characteristics</b>						
Drain-Source Breakdown Voltage	V <sub>(BR)DSS</sub>	V <sub>GS</sub> =0V, I <sub>D</sub> = 250μA	30	-	-	V
Gate leakage Current	I <sub>GSS</sub>	V <sub>GS</sub> =±12V, V <sub>DS</sub> =0V	-	-	±10	μA
Drain Cut-off Current	I <sub>BSS</sub>	V <sub>DS</sub> =30V, V <sub>GS</sub> =0V	-	-	1	μA
Gate Threshold Voltage	V <sub>GS(th)</sub>	V <sub>DS</sub> =V <sub>GS</sub> , I <sub>D</sub> =250μA	0.7	-	1.1	V
Drain-Source On-state Resistance <sup>3</sup>	R <sub>DS(on)</sub>	V <sub>GS</sub> =4.5 V, I <sub>D</sub> =0.6A	-	0.31	0.50	Ω
		V <sub>GS</sub> =2.5 V, I <sub>D</sub> =0.3A	-	0.40	0.68	Ω
<b>Dynamic Characteristics<sup>4</sup></b>						
Input Capacitance	C <sub>iss</sub>	V <sub>DS</sub> = 15V, V <sub>GS</sub> = 0V, f = 1MHz	-	40	-	pF
Output Capacitance	C <sub>oss</sub>		-	8	-	
Reverse Transfer Capacitance	C <sub>rss</sub>		-	3.5	-	
<b>Switching Characteristics<sup>4</sup></b>						
Total Gate Charge	Q <sub>g</sub>	V <sub>GS</sub> = 4.5V, V <sub>DS</sub> = 15V, I <sub>D</sub> = 0.6A	-	0.85	-	nC
Gate-Source Charge	Q <sub>gs</sub>		-	0.11	-	
Gate-Drain Charge	Q <sub>gd</sub>		-	0.16	-	
Turn-On Delay Time	t <sub>d(on)</sub>	V <sub>GS</sub> =4.5V, V <sub>DD</sub> = 15V, I <sub>D</sub> = 0.6A, R <sub>G</sub> = 3Ω	-	6.2	-	ns
Rise Time	t <sub>r</sub>		-	9	-	
Turn-Off Delay Time	t <sub>d(off)</sub>		-	21	-	
Fall Time	t <sub>f</sub>		-	32	-	
<b>Drain-Source Body Diode Characteristics</b>						
Diode Forward Voltage <sup>3</sup>	V <sub>SD</sub>	I <sub>S</sub> =0.6A, V <sub>GS</sub> =0V	-	-	1.2	V
Continuous Source Current	I <sub>S</sub>	-	-	-	0.6	A

**Notes:**

1. Repetitive rating, pulse width limited by junction temperature T<sub>J(MAX)</sub>=150°C.
2. The data tested by surface mounted on a 1 inch<sup>2</sup> FR-4 board with 2OZ copper, The value in any given application depends on the user's specific board design.
3. Pulse Test: Pulse width≤300μs, duty cycle≤2%.
4. This value is guaranteed by design hence it is not included in the production test.

### Typical Characteristics

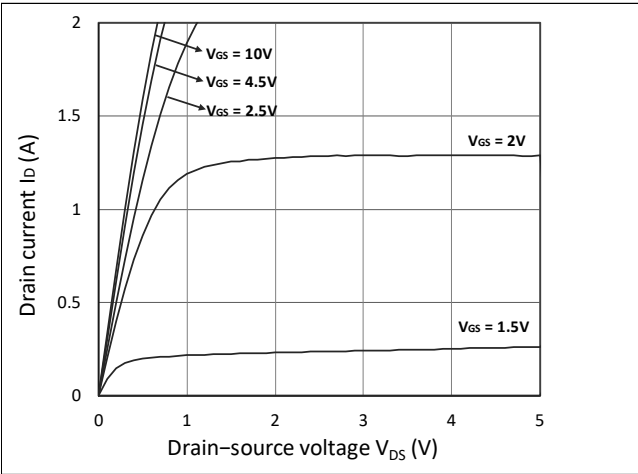

Figure 1. Output Characteristics

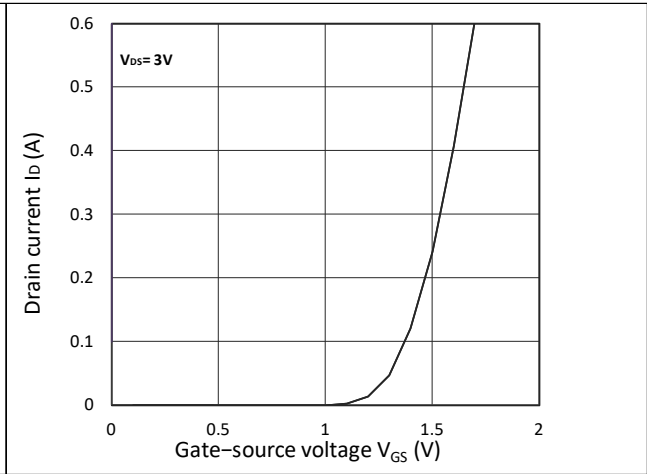

Figure 2. Transfer Characteristics

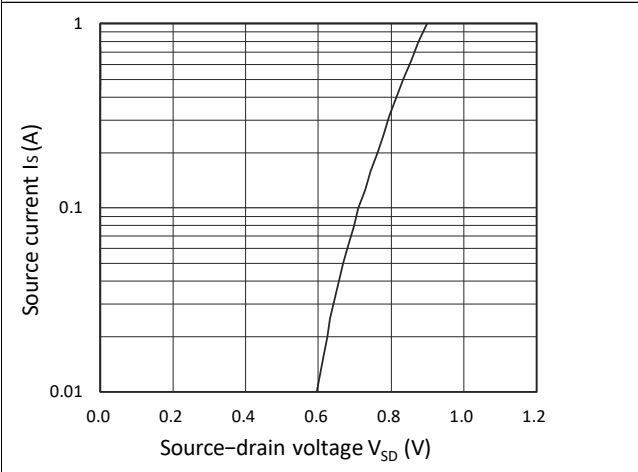

Figure 3. Forward Characteristics of Reverse

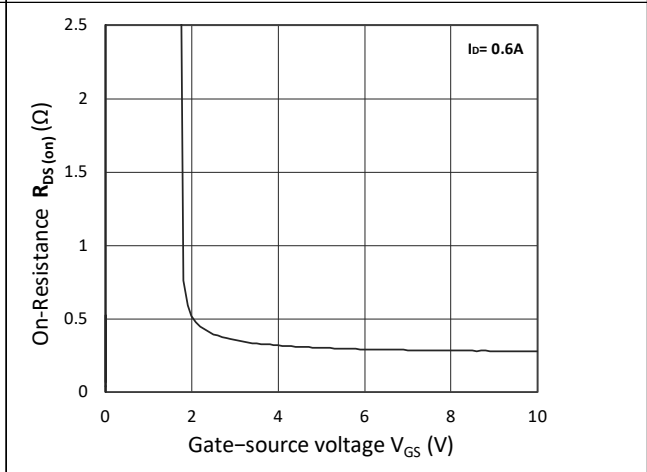

Figure 4.  $R_{DS(ON)}$  vs.  $V_{GS}$

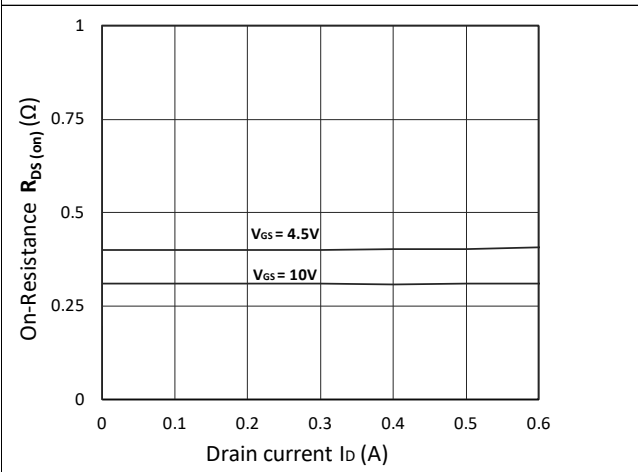

Figure 5.  $R_{DS(ON)}$  vs.  $I_D$

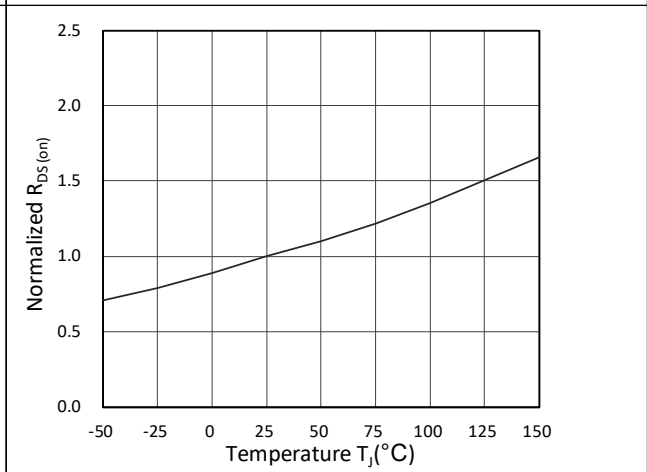
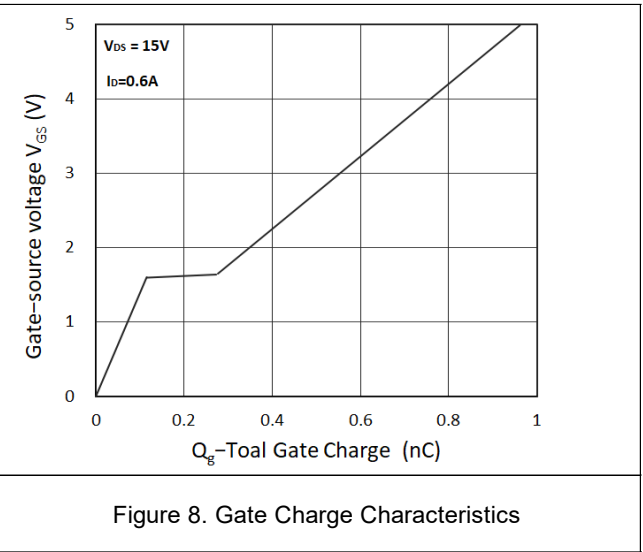
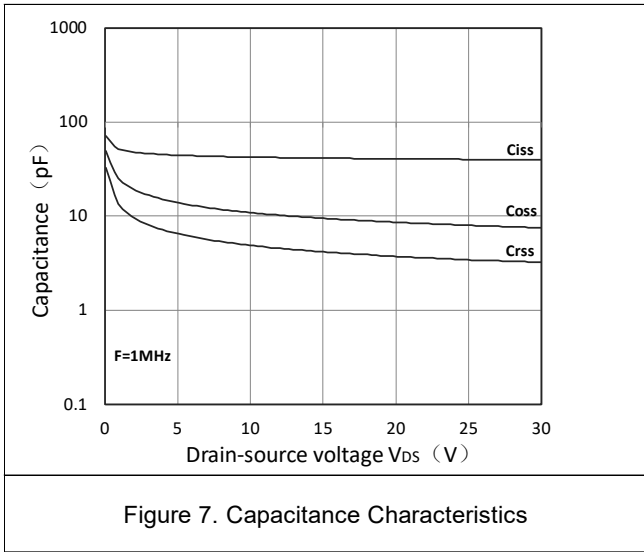
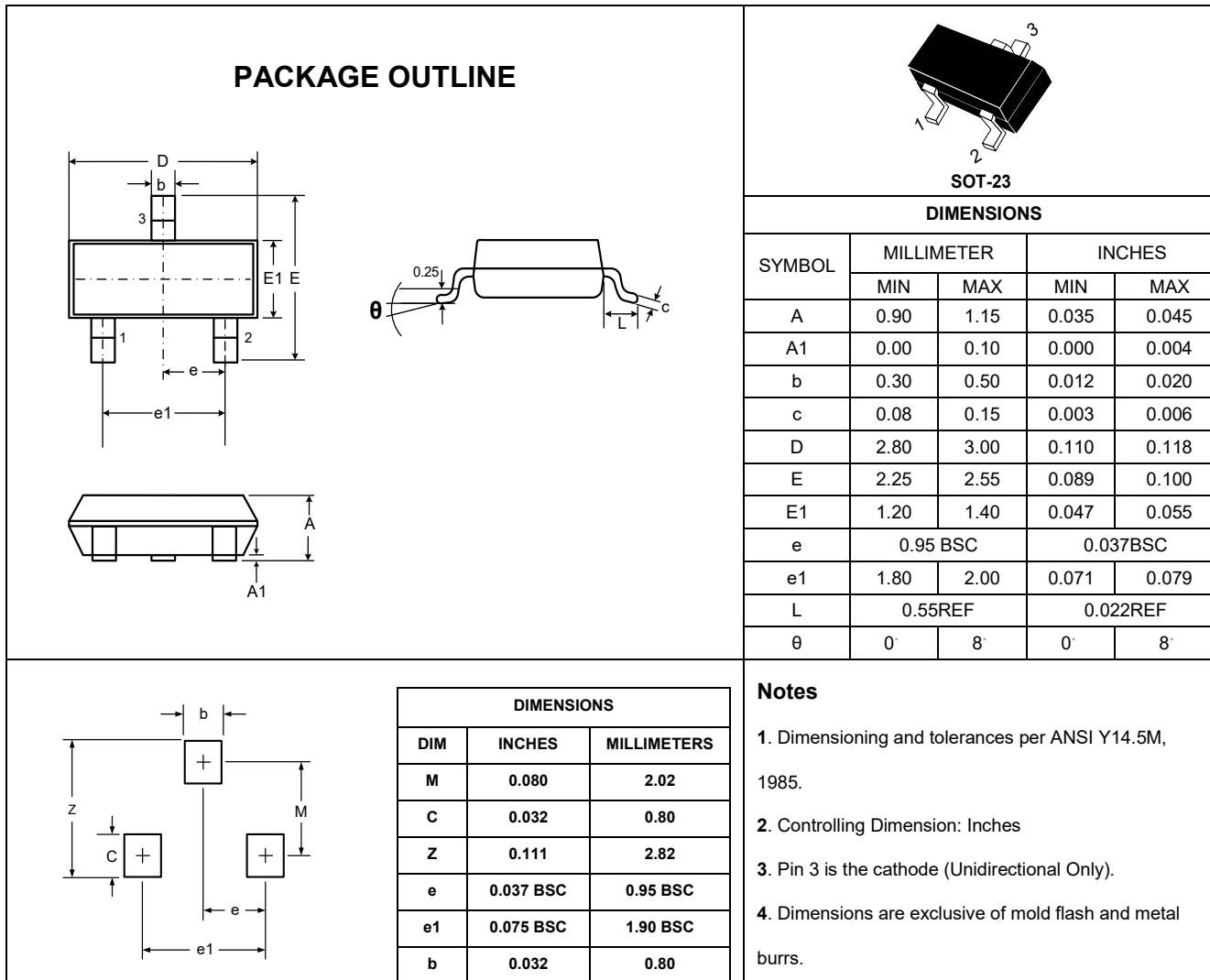

Figure 6. Normalized  $R_{DS(ON)}$  vs. Temperature



## Outline Drawing – SOT-23



## Marking Codes

Part Number	WM03N06M
Marking Code	

## Package Information

Qty: 3k/Reel

## CONTACT INFORMATION

No.1001, Shiwan (7) Road, Pudong District, Shanghai, P.R.China.201207

Tel: 86-21-68969993 Fax: 86-21-50757680 Email: [market@way-on.com](mailto:market@way-on.com)

WAYON website: <http://www.way-on.com>

For additional information, please contact your local Sales Representative.



® is registered trademark of Wayon Corporation.

Specifications are subject to change without notice.  
The device characteristics and parameters in this data sheet can and do vary in different applications and actual device performance may vary over time.  
Users should verify actual device performance in their specific applications.