

N-Channel Trench MOSFET

Features

- $V_{DS} = 30V$, $I_D = 0.1A$
 $R_{DS(on)} < 3\Omega @ V_{GS} = 4.5V$
 $R_{DS(on)} < 4\Omega @ V_{GS} = 2.5V$
- Very Fast Switching
- Trench MOSFET Technology
- Low Threshold Voltage
- Pb Free Device
- ESD Protected

Mechanical Characteristics

- SOT-323 Package
- Marking : Making Code
- RoHS Compliant

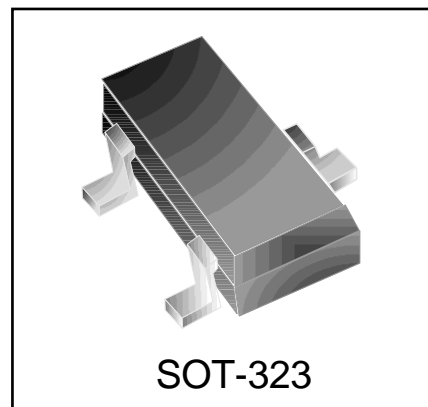

Schematic & PIN Configuration

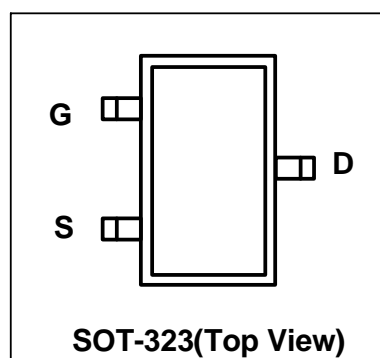
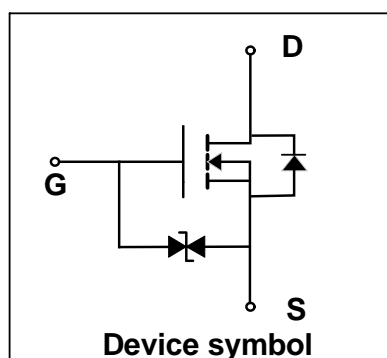

Absolute Maximum Rating

Parameter	Symbol	Value	Unit
Drain-Source Voltage	V_{DS}	30	V
Gate-Source Voltage	V_{GS}	± 20	V
Continuous Drain Current	I_D	100	mA
Pulsed Drain Current ¹	I_{DM}	300	mA
Power Dissipation	P_D	200	mW
Junction Temperature	T_J	150	$^{\circ}C$
Storage Temperature	T_{STG}	-55 to +150	$^{\circ}C$
Thermal Resistance from Junction to Ambient ²	$R_{\theta JA}$	625	$^{\circ}C/W$

Electrical Characteristics ($T_{amb}=25^{\circ}C$ unless otherwise noted)

Parameter	Symbol	Test Condition	Min.	Typ.	Max.	Unit
Static Characteristics						
Drain-Source Breakdown Voltage	BV_{DSS}	$V_{GS} = 0V, I_D = 250\mu A$	30	-	-	V
Zero Gate Voltage Drain Current	I_{DSS}	$V_{DS} = 30V, V_{GS} = 0V$	-	-	1	μA
Gate-Body Leakage Current	I_{GSS}	$V_{DS} = 0V, V_{GS} = \pm 20V$	-	-	± 5	μA
Gate Threshold Voltage ³	$V_{GS(th)}$	$V_{DS} = V_{GS}, I_D = 250\mu A$	0.7	-	1.4	V
Drain-Source on-State Resistance ³	$R_{DS(on)}$	$V_{GS} = 4.5V, I_D = 10mA$	-	1	3	Ω
		$V_{GS} = 2.5V, I_D = 1mA$	-	1.9	4	
Dynamic Characteristics						
Input Capacitance	C_{iss}	$V_{GS} = 0V, V_{DS} = 5V,$ $f = 1MHz$	-	30	-	pF
Output Capacitance	C_{oss}		-	7.7	-	
Reverse Transfer Capacitance	C_{rss}		-	3.5	-	
Switching Characteristics						
Turn-on Delay Time ⁴	$t_{d(on)}$	$V_{GS} = 5V, V_{DD} = 10V,$ $R_L = 500\Omega, R_{GEN} = 10\Omega$	-	15	-	nS
Turn-on Rise Time ⁴	t_r		-	35	-	
Turn-off Delay Time ⁴	$t_{d(off)}$		-	80	-	
Turn-off Fall Time ⁴	t_f		-	80	-	
Drain-Source Body Diode Characteristics						
Body Diode Voltage	V_{SD}	$I_S = 0.1A, V_{GS} = 0V$	-	-	1.4	V

Notes:

1. Repetitive Rating: Pulse width limited by maximum junction temperature.
2. Surface mounted on FR4 board using 1 square inch pad size, 1oz single-side copper.
3. Pulse Test: Pulse width $\leq 300\mu s$, duty cycle $\leq 2\%$.
4. Guaranteed by design, not subject to product

Typical Characteristics

Figure 1. Output Characteristics

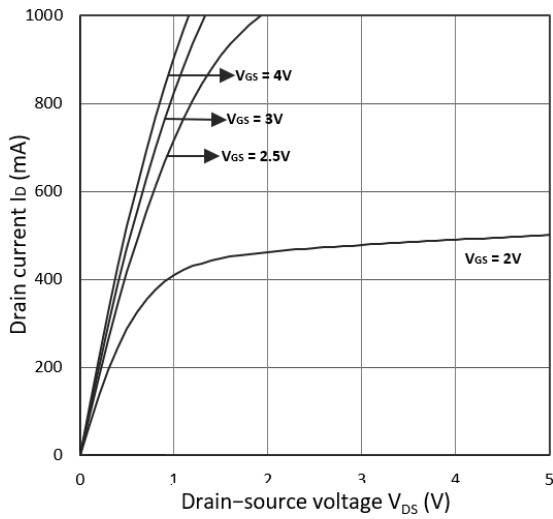

Figure 3. $R_{DS(ON)}$ vs. I_D

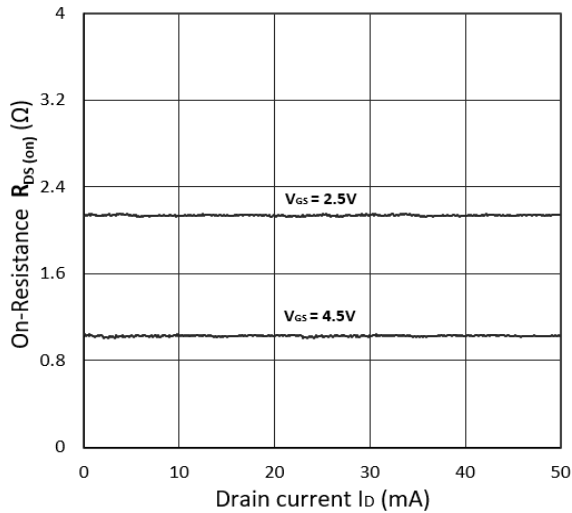

Figure 5. I_S vs. V_{SD}

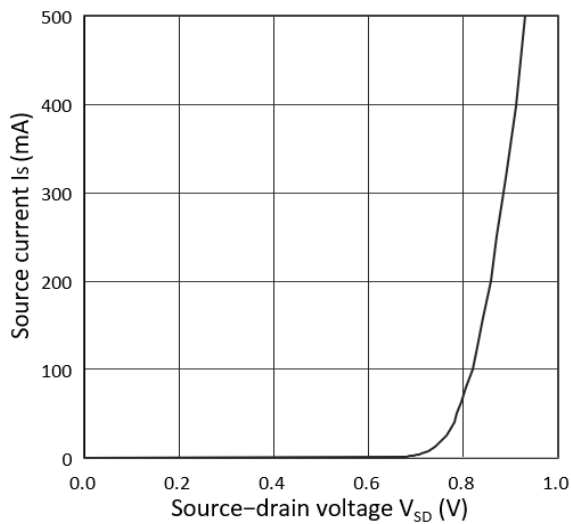

Figure 2. Transfer Characteristics

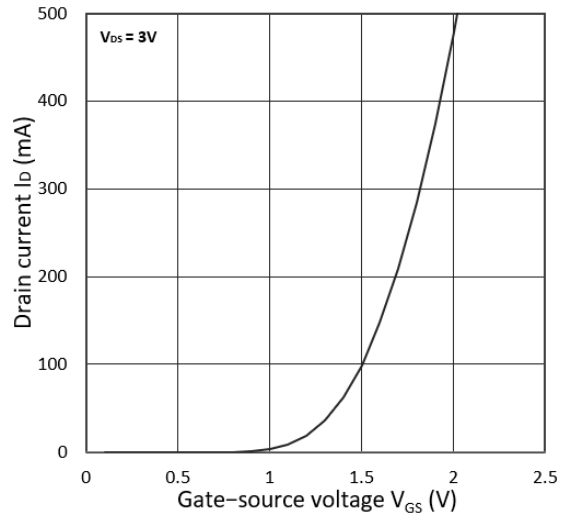

Figure 4. $R_{DS(ON)}$ vs. V_{GS}

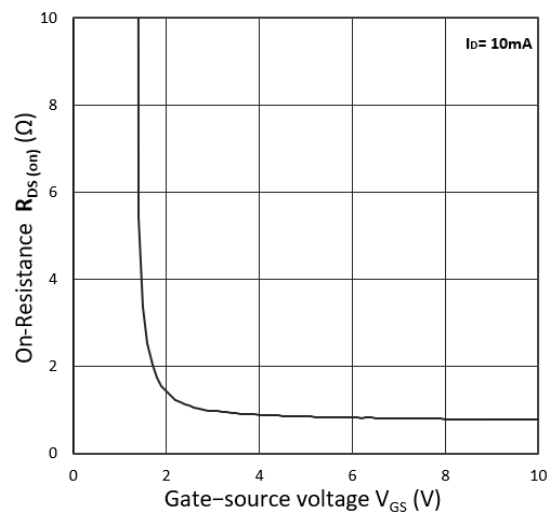
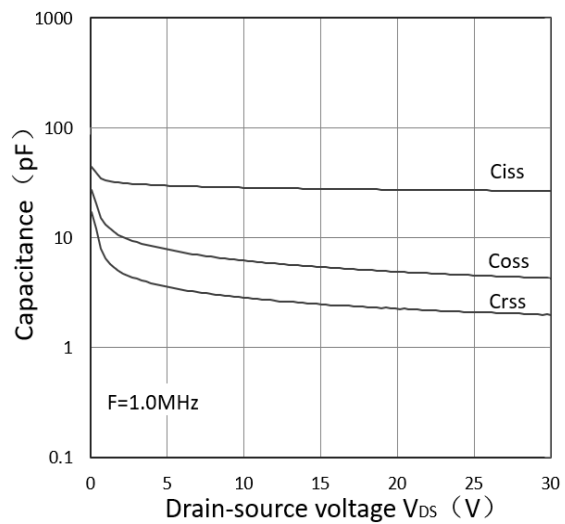

Figure 6. Capacitance Characteristics



Outline Drawing – SOT-323

PACKAGE OUTLINE

SOT-323

DIMENSIONS

SYMBOL	MILLIMETER		INCHES	
	MIN	MAX	MIN	MAX
A	0.900	1.100	0.035	0.043
A1	0.000	0.100	0.000	0.004
D	2.000	2.200	0.079	0.087
b	0.300	0.500	0.012	0.020
c	0.100	0.150	0.004	0.006
E	2.150	2.450	0.085	0.096
E1	1.150	1.350	0.045	0.053
e	0.650TYP		0.026TYP	
L	0.525 REF		0.021 REF	
θ	0	8°	0	8°

DIMENSIONS		
DIM	INCHES	MILLIMETERS
M	0.076	1.90
C	0.036	0.9
Z	0.108	2.7
e	0.026	0.65
e1	0.052	1.30
b	0.028	0.7

Notes

1. Dimensioning and tolerances per ANSI Y14.5M, 1985.
2. Controlling Dimension: Inches
3. Pin 3 is the cathode (Unidirectional Only).
4. Dimensions are exclusive of mold flash and metal burrs.

Marking Codes

Part Number	WM03N01G
Marking Code	

Package Information

Qty: 3k/Reel

CONTACT INFORMATION

No.1001, Shiwan (7) Road, Pudong District, Shanghai, P.R.China.201207

Tel: 86-21-68969993 Fax: 86-21-50757680 Email: market@way-on.com

WAYON website: <http://www.way-on.com>

For additional information, please contact your local Sales Representative.

WAYON® is registered trademark of Wayon Corporation.

Specifications are subject to change without notice.
The device characteristics and parameters in this data sheet can and do vary in different applications and actual device performance may vary over time.
Users should verify actual device performance in their specific applications.