

8-Bit Dual-Supply Bus Transceiver with Configurable Voltage Translation and 3-State Output

1 FEATURES

- Control Input V_{IH}/V_{IL} Levels are Referenced to V_{CCA} Voltage
- Power-Supply Range: V_{CCA} and V_{CCB} : 1.65V to 5.5V
- Latch-Up Performance Exceeds 100mA per JESD 78, Class II
- V_{CC} Isolation: If Either V_{CC} is at GND, Both Ports are in the High-Impedance State
- I_{OFF} : Supports Partial-Power-Down Mode Operation
- Compatible with RS8T245
- Optimized Power Up Structure to Suppress Burr
- Extended Temperature: -40°C to +125°C

2 APPLICATIONS

- Handset
- Smartphone
- Tablet
- Desktop PC

3 DESCRIPTIONS

This 8-bit non-inverting bus transceiver is a bidirectional voltage-level translator and can be used to establish digital switching compatibility between mixed-voltage systems. It uses two separate configurable power-supply rails, Both $V_{CC(A)}$ and $V_{CC(B)}$ supporting operating voltages from 1.65 V to 5.5 V, A ports, DIR and \overline{OE} tracks the V_{CCA} supply and B ports tracks the V_{CCB} supply. This allows the support of both lower and higher logic signal levels while providing bidirectional translation capabilities between any of the 1.8V, 2.5V, 3.3V and 5.5V voltage nodes.

The RS8T245A is designed for asynchronous communication between two data buses. The logic levels of the direction-control (DIR) input and the output-enable (\overline{OE}) input activate either the B-port outputs or the A-port outputs or place both output ports into the high-impedance mode. The device transmits data from the A bus to the B bus when the B-port outputs are activated, and from the B bus to the A bus when the A-port outputs are activated. The input circuitry on both A and B ports is always active and must have a logic HIGH or LOW level applied to prevent excess I_{CC} and I_{CCZ} .

This device is fully specified for partial-power-down applications using I_{OFF} . The I_{OFF} circuitry disables the outputs, preventing damaging current backflow through the device when it is powered down.

The V_{CC} isolation feature ensures that if either V_{CC} input is at GND, all outputs are in the high-impedance state.

To ensure the high-impedance state during power up or power down, \overline{OE} should be tied to V_{CC} through a pullup resistor, the minimum value of the resistor is determined by the current-sinking capability of the driver.

The RS8T245A is designed so that the control pins (DIR and \overline{OE}) are supplied by V_{CCA} . It operates over an ambient temperature range of -40°C to +125°C.

Device Information (1)

PART NUMBER	PACKAGE	BODY SIZE (NOM)
RS8T245A	TSSOP-24(24)	7.80mm×4.40mm

(1) For all available packages, see the orderable addendum at the end of the data sheet.

4 Functional Block Diagram

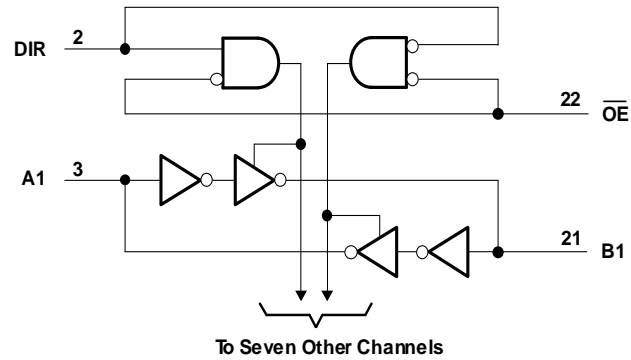

Function Table

CONTROL INPUTS		OUTPUT CIRCUITS		OPERATION
\overline{OE}	DIR	A PORT	B PORT	
L	L	Enabled	Hi-Z	B data to A bus
L	H	Hi-Z	Enabled	A data to B bus
H	X	Hi-Z	Hi-Z	Isolation

Table of Contents

1 FEATURES	1
2 APPLICATIONS	1
3 DESCRIPTIONS	1
4 Functional Block Diagram	2
5 Revision History	4
6 PACKAGE/ORDERING INFORMATION ⁽¹⁾	5
7 PIN CONFIGURATIONS	6
8 SPECIFICATIONS	7
8.1 Absolute Maximum Ratings	7
8.2 ESD Ratings	7
8.3 Recommended Operating Conditions	8
8.4 Electrical Characteristics	9
8.5 Switching Characteristics	10
8.5.1 $V_{CCA}=1.8V\pm 0.15V$	10
8.5.2 $V_{CCA}=2.5V\pm 0.2V$	10
8.5.3 $V_{CCA}=3.3V\pm 0.3V$	11
8.5.4 $V_{CCA}=5V\pm 0.5V$	11
8.6 Operating Characteristics	11
8.7 Typical Characteristics	12
9 Parameter Measurement Information	13
10 Application Information	14
11 PACKAGE OUTLINE DIMENSIONS	15
12 TAPE AND REEL INFORMATION	16

5 Revision History

Note: Page numbers for previous revisions may differ from page numbers in the current version.

VERSION	Change Date	Change Item
A.1	2023/07/28	Initial version completed

6 PACKAGE/ORDERING INFORMATION (1)

PRODUCT	ORDERING NUMBER	TEMPERATURE RANGE	PACKAGE LEAD	PACKAGE MARKING (2)	MSL (3)	PACKAGE OPTION
RS8T245A	RS8T245AXTSS24-G	-40°C ~+125°C	TSSOP-24	RS8T245A	MSL1	Tape and Reel,4000

NOTE:

- (1) This information is the most current data available for the designated devices. This data is subject to change without notice and revision of this document. For browser-based versions of this data sheet, refer to the right-hand navigation.
- (2) There may be additional marking, which relates to the lot trace code information(data code and vendor code), the logo or the environmental category on the device.
- (3) MSL, The Moisture Sensitivity Level rating according to the JEDEC industry standard classifications.

7 PIN CONFIGURATIONS

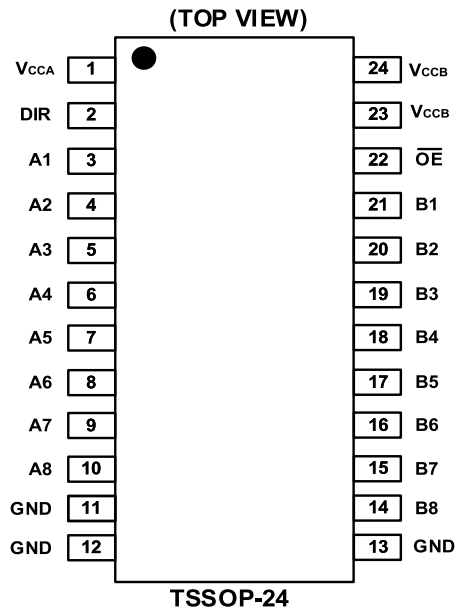

PIN DESCRIPTION

PIN	NAME	TYPE ⁽¹⁾	FUNCTION
TSSOP-24			
3	A1	I/O	Input/output A1. Reference to V _{CCA} .
4	A2	I/O	Input/output A2. Reference to V _{CCA} .
5	A3	I/O	Input/output A3. Reference to V _{CCA} .
6	A4	I/O	Input/output A4. Reference to V _{CCA} .
7	A5	I/O	Input/output A5. Reference to V _{CCA} .
8	A6	I/O	Input/output A6. Reference to V _{CCA} .
9	A7	I/O	Input/output A7. Reference to V _{CCA} .
10	A8	I/O	Input/output A8. Reference to V _{CCA} .
14	B8	I/O	Input/output B8. Reference to V _{CCB} .
15	B7	I/O	Input/output B7. Reference to V _{CCB} .
16	B6	I/O	Input/output B6. Reference to V _{CCB} .
17	B5	I/O	Input/output B5. Reference to V _{CCB} .
18	B4	I/O	Input/output B4. Reference to V _{CCB} .
19	B3	I/O	Input/output B3. Reference to V _{CCB} .
20	B2	I/O	Input/output B2. Reference to V _{CCB} .
21	B1	I/O	Input/output B1. Reference to V _{CCB} .
2	DIR	I	Direction-control signal.
11,12,13	GND	G	Ground.
22	\overline{OE}	I	Output Enable (Active Low). Pull \overline{OE} high to place all outputs in 3-state mode. Referenced to V _{CCA} .
1	V _{CCA}	P	A-port supply voltage. $1.65V \leq V_{CCA} \leq 5.5V$
23,24	V _{CCB}	P	B-port supply voltage. $1.65V \leq V_{CCB} \leq 5.5V$

(1) I=input, O=output, I/O=input and output, P=power

8 SPECIFICATIONS

8.1 Absolute Maximum Ratings

Over operating free-air temperature range (unless otherwise noted) ⁽¹⁾

SYMBOL	PARAMETER	MIN	MAX	UNIT		
V _{CCA}	Supply Voltage Range	-0.5	6.5	V		
V _{CCB}	Supply Voltage Range	-0.5	6.5	V		
V _I ⁽²⁾	Input Voltage Range	A port	-0.5	6.5	V	
		B port	-0.5	6.5		
		Control inputs	-0.5	6.5		
V _O ⁽²⁾	Voltage range applied to any output in the high-impedance or power-off state	A port	-0.5	6.5	V	
		B port	-0.5	6.5		
V _O ⁽²⁾⁽³⁾	Voltage range applied to any output in the high or low state	A port	-0.5	V _{CCA} +0.5	V	
		B port	-0.5	V _{CCB} +0.5		
I _{IK}	Input clamp current	V _I <0		-50	mA	
I _{OK}	Output clamp current	V _O <0		-50	mA	
I _O	Continuous output current			±50	mA	
	Continuous current through V _{CCA} , V _{CCB} or GND			±100	mA	
θ _{JA}	Package thermal impedance ⁽⁴⁾	TSSOP-24		35	°C/W	
T _J	Junction Temperature ⁽⁵⁾			-40	150	°C
T _{stg}	Storage temperature			-65	150	

(1) Stresses beyond those listed under *Absolute Maximum Ratings* may cause permanent damage to the device. These are stress ratings only, which do not imply functional operation of the device at these or any other conditions beyond those indicated under *Recommended Operating Conditions*. Exposure to absolute-maximum-rated conditions for extended periods may affect device reliability.

(2) The input and output negative-voltage ratings may be exceeded if the input and output current ratings are observed.

(3) The value of V_{CCA} and V_{CCB} are provided in the recommended operating conditions table.

(4) The package thermal impedance is calculated in accordance with JESD-51.

(5) The maximum power dissipation is a function of T_{J(MAX)}, R_{θJA}, and T_A. The maximum allowable power dissipation at any ambient temperature is P_D = (T_{J(MAX)} - T_A) / R_{θJA}. All numbers apply for packages soldered directly onto a PCB.

8.2 ESD Ratings

The following ESD information is provided for handling of ESD-sensitive devices in an ESD protected area only.

		VALUE	UNIT
V _(ESD)	Electrostatic discharge	Human-body model (HBM), MIL-STD-883K METHOD 3015.9	±2000
		Charged-device model (CDM), ANSI/ESDA/JEDEC JS-002-2018	±1000
		Machine model (MM), JESD22-A115C (2010)	±200



ESD SENSITIVITY CAUTION

ESD damage can range from subtle performance degradation to complete device failure. Precision integrated circuits may be more susceptible to damage because very small parametric changes could cause the device not to meet its published specifications.

8.3 Recommended Operating Conditions

V_{CCI} is the supply voltage associated with the input port. V_{CCO} is the supply voltage associated with the output port.

PARAMETER		$V_{CCI}^{(1)}$	$V_{CCO}^{(2)}$	MIN	TYP	MAX	UNIT
Supply voltage ⁽¹⁾	V_{CCA}			1.65		5.5	V
	V_{CCB}			1.65		5.5	
High-level input Voltage (V_{IH})	Data inputs ⁽⁵⁾	1.65V to 1.95V		$V_{CCI} \times 0.75$			V
		2.3V to 2.7V		$V_{CCI} \times 0.7$			
		3V to 3.6V		$V_{CCI} \times 0.7$			
		4.5V to 5.5V		$V_{CCI} \times 0.7$			
Low-level input Voltage (V_{IL})	Data inputs ⁽⁵⁾	1.65V to 1.95V				$V_{CCI} \times 0.35$	V
		2.3V to 2.7V				$V_{CCI} \times 0.3$	
		3V to 3.6V				$V_{CCI} \times 0.3$	
		4.5V to 5.5V				$V_{CCI} \times 0.3$	
High-level input Voltage (V_{IH})	Control inputs (referenced to V_{CCA}) ⁽⁶⁾	1.65V to 1.95V		$V_{CCA} \times 0.75$			V
		2.3V to 2.7V		$V_{CCA} \times 0.7$			
		3V to 3.6V		$V_{CCA} \times 0.7$			
		4.5V to 5.5V		$V_{CCA} \times 0.7$			
Low-level input Voltage (V_{IL})	Control inputs (referenced to V_{CCA}) ⁽⁶⁾	1.65V to 1.95V				$V_{CCA} \times 0.35$	V
		2.3V to 2.7V				$V_{CCA} \times 0.3$	
		3V to 3.6V				$V_{CCA} \times 0.3$	
		4.5V to 5.5V				$V_{CCA} \times 0.3$	
Input voltage (V_I)	Control inputs ⁽⁴⁾			0		5.5	V
Input/output voltage ($V_{I/O}$)	Active state			0		V_{CCO}	V
	3-state			0		5.5	V
High-level output current (I_{OH})			1.65V to 1.95V			-4	mA
			2.3V to 2.7V			-8	
			3V to 3.6V			-24	
			4.5V to 5.5V			-32	
Low-level output current (I_{OL})			1.65V to 1.95V			4	mA
			2.3V to 2.7V			8	
			3V to 3.6V			24	
			4.5V to 5.5V			32	
Input transition rise or fall rate($\Delta t/\Delta v$)	Data inputs ⁽³⁾	1.65V to 1.95V				20	ns/V
		2.3V to 2.7V				20	
		3V to 3.6V				10	
		4.5V to 5.5V				5	
T_A Operating free-air temperature				-40		125	°C

(1) V_{CCI} is the V_{CC} associated with the data input port.

(2) V_{CCO} is the V_{CC} associated with the output port.

(3) All unused or driven (floating) data inputs (I/Os) of the device must be held at logic HIGH or LOW (preferably V_{CCI} or GND) to ensure proper device operation and minimize power.

(4) All unused control inputs must be held at V_{CCA} or GND to ensure proper device operation and minimize power consumption.

(5) For V_{CCI} values not specified in the data sheet, $V_{IH} \text{ min} = V_{CCI} \times 0.7 \text{ V}$, $V_{IL} \text{ max} = V_{CCI} \times 0.3 \text{ V}$.

(6) For V_{CCA} values not specified in the data sheet, $V_{IH} \text{ min} = V_{CCA} \times 0.7 \text{ V}$, $V_{IL} \text{ max} = V_{CCA} \times 0.3 \text{ V}$.

8.4 Electrical Characteristics

over recommended operating free-air temperature range (unless otherwise noted) ^{(1) (2)}

PARAMETER	CONDITIONS	V _{CCA}	V _{CCB}	TEMP	MIN ⁽³⁾	TYP ⁽⁴⁾	MAX ⁽³⁾	UNIT	
V _{OH}	I _{OH} = -100 μA V _I = V _{IH}	1.65V to 4.5V	1.65V to 4.5V	Full	V _{CCO} - 0.1			V	
	I _{OH} = -4mA V _I = V _{IH}	1.65V	1.65V		1.2				
	I _{OH} = -8mA V _I = V _{IH}	2.3V	2.3V		1.9				
	I _{OH} = -24mA V _I = V _{IH}	3V	3V		2.4				
	I _{OH} = -32mA V _I = V _{IH}	4.5V	4.5V		3.8				
V _{OL}	I _{OL} = 100 μA V _I = V _{IL}	1.65V to 4.5V	1.65V to 4.5V					0.1	V
	I _{OL} = 4mA V _I = V _{IL}	1.65V	1.65V					0.45	
	I _{OL} = 8mA V _I = V _{IL}	2.3V	2.3V					0.3	
	I _{OL} = 24mA V _I = V _{IL}	3V	3V					0.55	
	I _{OL} = 32mA V _I = V _{IL}	4.5V	4.5V					0.55	
I _I DIR	V _I = V _{CCA} or GND	1.65V to 5.5V	1.65V to 5.5V	+25°C			±1	μA	
				Full			±2		
I _{off} A or B Port	V _I or V _O = 0 to 5.5V	0V	0V to 5.5V	+25°C			±1	μA	
		0V to 5.5V	0V	Full			±2		
I _{OZ} ⁽⁵⁾ A or B Port	V _O = V _{CCO} or GND, \overline{OE} = V _{IH}	1.65V to 5.5V	1.65V to 5.5V	+25°C			±1	μA	
				Full			±2		
I _{CCA} V _{CCA} supply current	V _I = V _{CCI} or GND ⁽⁶⁾ I _O = 0	1.65V to 5.5V	1.65V to 5.5V	Full			15	μA	
		5V	0V	Full			15		
		0V	5V	Full			-2		
I _{CCB} V _{CCB} supply current	V _I = V _{CCI} or GND ⁽⁶⁾ I _O = 0	1.65V to 5.5V	1.65V to 5.5V	Full			15	μA	
		5V	0V	Full			-2		
		0V	5V	Full			15		
I _{CCA} + I _{CCB} Combined supply current	V _I = V _{CCI} or GND I _O = 0	1.65V to 5.5V	1.65V to 5.5V	Full			25	μA	
ΔI _{CCA}	A port	3V to 5.5V	3V to 5.5V	Full			50	μA	
	DIR								One A port at V _{CCA} - 0.6 V, DIR at V _{CCA} , B port = open
ΔI _{CCB}	B port	3V to 5.5V	3V to 5.5V	Full			50	μA	
	DIR								One B port at V _{CCB} - 0.6 V, DIR at GND, A port = open
C _I Control inputs	V _I = V _{CCA} or GND	3.3V	3.3V	+25°C		7.3		pF	
C _{IO}	A port	3.3V	3.3V	+25°C		7.6		pF	
	B port	3.3V	3.3V	+25°C		7.6			

(1) V_{CCI} is the V_{CC} associated with the input port.

(2) V_{CCO} is the V_{CC} associated with the output port.

(3) Limits are 100% production tested at 25°C. Limits over the operating temperature range are ensured through correlations using statistical quality control (SQC) method.

(4) Typical values represent the most likely parametric norm as determined at the time of characterization. Actual typical values may vary over time and will also depend on the application and configuration.

(5) For I/O ports, the parameter I_{OZ} includes the input leakage current.

(6) Hold all unused data inputs of the device at V_{CCI} or GND to assure proper device operation.

8.5 Switching Characteristics

8.5.1 $V_{CCA}=1.8V\pm 0.15V$

over recommended operating free-air temperature range, Full= $-40^{\circ}C$ to $125^{\circ}C$.

PARAMETER	FROM (INPUT)	TO (OUTPUT)	TEMP	$V_{CCB}=1.8V \pm 0.15V^{(1)}$		$V_{CCB}=2.5V \pm 0.2V^{(1)}$		$V_{CCB}=3.3V \pm 0.3V^{(1)}$		$V_{CCB}=5V \pm 0.5V^{(1)}$		UNIT
				MIN	MAX	MIN	MAX	MIN	MAX	MIN	MAX	
t_{PLH}	An	Bn	Full	4.5	28.5	3.4	21	2.5	18.4	1.8	15	ns
t_{PHL}												
t_{PLH}	Bn	An	Full	6.2	30	4.2	23.2	3.2	19.6	2.5	16.6	ns
t_{PHL}												
t_{PHZ}	\overline{OE}	An	Full	2.5	31.5	2.5	20	2.5	19.4	2.5	18.5	ns
t_{PLZ}												
t_{PHZ}	\overline{OE}	Bn	Full	3.8	32	3.6	22	3.5	21.2	3.4	19.8	ns
t_{PLZ}												
t_{PZH}	\overline{OE}	An	Full	2.4	34.5	2.4	22	2.4	20	2.4	19.5	ns
t_{PZL}												
t_{PZH}	\overline{OE}	Bn	Full	3.8	36	3.6	23.5	3.5	22.4	3.4	20.8	ns
t_{PZL}												

(1) This parameter is ensured by design and/or characterization and is not tested in production.

8.5.2 $V_{CCA}=2.5V\pm 0.2V$

over recommended operating free-air temperature range, Full= $-40^{\circ}C$ to $125^{\circ}C$.

PARAMETER	FROM (INPUT)	TO (OUTPUT)	TEMP	$V_{CCB}=1.8V \pm 0.15V^{(1)}$		$V_{CCB}=2.5V \pm 0.2V^{(1)}$		$V_{CCB}=3.3V \pm 0.3V^{(1)}$		$V_{CCB}=5V \pm 0.5V^{(1)}$		UNIT
				MIN	MAX	MIN	MAX	MIN	MAX	MIN	MAX	
t_{PLH}	An	Bn	Full	4.1	27	3.5	16	2.4	14.5	1.8	13.2	ns
t_{PHL}												
t_{PLH}	Bn	An	Full	5.8	26.6	4.2	15.8	3.2	13.5	2.5	12.8	ns
t_{PHL}												
t_{PHZ}	\overline{OE}	An	Full	2.2	24.1	2.2	12.5	2.2	11.5	2.2	9.8	ns
t_{PLZ}												
t_{PHZ}	\overline{OE}	Bn	Full	3.7	26.3	3.5	13.8	3.4	13.2	3.3	11.3	ns
t_{PLZ}												
t_{PZH}	\overline{OE}	An	Full	2.1	29	2.1	17.8	2.1	14.7	2.1	14.1	ns
t_{PZL}												
t_{PZH}	\overline{OE}	Bn	Full	3.7	32.3	3.5	17.3	3.4	16.2	3.3	15.6	ns
t_{PZL}												

(1) This parameter is ensured by design and/or characterization and is not tested in production.

8.5.3 $V_{CCA}=3.3V\pm 0.3V$

over recommended operating free-air temperature range, Full=-40°C to 125°C.

PARAMETER	FROM (INPUT)	TO (OUTPUT)	TEMP	$V_{CCB}=1.8V \pm 0.15V^{(1)}$		$V_{CCB}=2.5V \pm 0.2V^{(1)}$		$V_{CCB}=3.3V \pm 0.3V^{(1)}$		$V_{CCB}=5V \pm 0.5V^{(1)}$		UNIT
				MIN	MAX	MIN	MAX	MIN	MAX	MIN	MAX	
t_{PLH}	An	Bn	Full	3.5	25.1	3.1	15.6	2.3	14.2	1.6	13	ns
t_{PHL}												
t_{PLH}	Bn	An	Full	4.1	26.5	3.8	15.7	3	13.3	2.3	12.5	ns
t_{PHL}												
t_{PHZ}	\overline{OE}	An	Full	1.8	24	1.8	13.3	1.8	11.5	1.8	9	ns
t_{PLZ}												
t_{PHZ}	\overline{OE}	Bn	Full	3.2	25.2	3.1	13.5	2.9	12.2	2.8	10.2	ns
t_{PLZ}												
t_{PZH}	\overline{OE}	An	Full	1.7	28.2	1.7	17.5	1.7	14.5	1.7	13.8	ns
t_{PZL}												
t_{PZH}	\overline{OE}	Bn	Full	3.2	29.7	3.1	16.8	2.9	16.1	2.8	14.1	ns
t_{PZL}												

(1) This parameter is ensured by design and/or characterization and is not tested in production.

8.5.4 $V_{CCA}=5V\pm 0.5V$

over recommended operating free-air temperature range, Full=-40°C to 125°C.

PARAMETER	FROM (INPUT)	TO (OUTPUT)	TEMP	$V_{CCB}=1.8V \pm 0.15V^{(1)}$		$V_{CCB}=2.5V \pm 0.2V^{(1)}$		$V_{CCB}=3.3V \pm 0.3V^{(1)}$		$V_{CCB}=5V \pm 0.5V^{(1)}$		UNIT
				MIN	MAX	MIN	MAX	MIN	MAX	MIN	MAX	
t_{PLH}	An	Bn	Full	3.5	25	3	14.5	2.2	13.8	1.5	12.8	ns
t_{PHL}												
t_{PLH}	Bn	An	Full	4.3	26	3.7	15.2	2.8	13.1	1.7	12.2	ns
t_{PHL}												
t_{PHZ}	\overline{OE}	An	Full	1.6	23.5	1.6	10.5	1.6	9.7	1.6	8.8	ns
t_{PLZ}												
t_{PHZ}	\overline{OE}	Bn	Full	2.2	24	2.1	11.7	1.9	10.8	1.8	9.6	ns
t_{PLZ}												
t_{PZH}	\overline{OE}	An	Full	1.5	23.4	1.5	15.2	1.5	13.1	1.5	12.5	ns
t_{PZL}												
t_{PZH}	\overline{OE}	Bn	Full	2.2	26.4	2.1	16.5	1.9	14.7	1.8	13.9	ns
t_{PZL}												

(1) This parameter is ensured by design and/or characterization and is not tested in production.

8.6 Operating Characteristics

$T_A=25^\circ C$

PARAMETER	TEST CONDITIONS	$V_{CCA}=V_{CCB}=1.8V$	$V_{CCA}=V_{CCB}=2.5V$	$V_{CCA}=V_{CCB}=3.3V$	$V_{CCA}=V_{CCB}=5V$	UNIT
		TYP	TYP	TYP	TYP	
$C_{pdA}^{(1)}$	A-port input, B-port output	3	4	5	8	pF
	B-port input, A-port output	18	24	32	48	
$C_{pdB}^{(1)}$	A-port input, B-port output	18	24	32	48	
	B-port input, A-port output	3	4	5	8	

(1) Power dissipation capacitance per transceiver

8.7 Typical Characteristics

NOTE: The graphs and tables provided following this note are a statistical summary based on a limited number of samples and are provided for informational purposes only.

At $T_A = +25^\circ\text{C}$, $V_{CCA}=5\text{V}$, $V_{CCB}=5\text{V}$, unless otherwise noted.

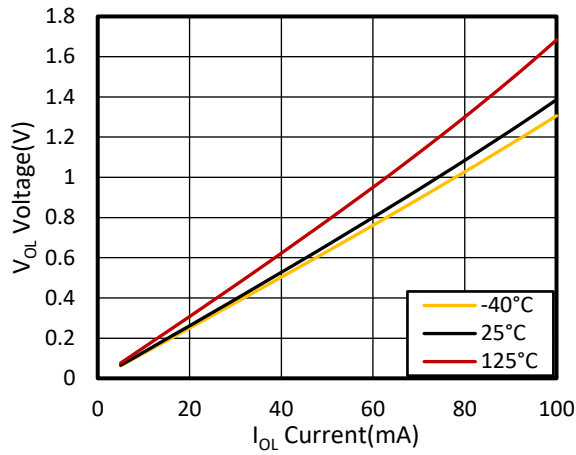

Figure 1. Voltage vs Current

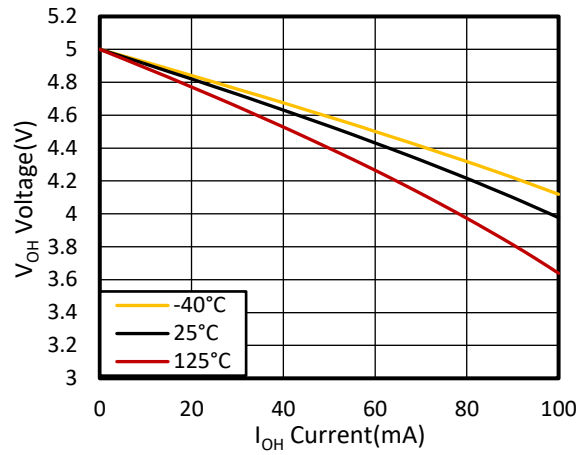
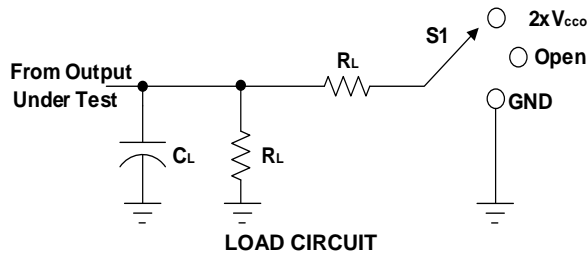

Figure 2. Voltage vs Current

9 Parameter Measurement Information



TEST	S1
t_{pd}	Open
t_{PLZ}/t_{PZL}	2 X V_{CC0}
t_{PHZ}/t_{PZH}	GND

V_{CC}	C_L	R_L	V_{TP}
$1.8V \pm 0.15V$	15pF	2k Ω	0.15V
$2.5V \pm 0.2V$	15pF	2k Ω	0.15V
$3.3V \pm 0.3V$	15pF	2k Ω	0.3V
$5V \pm 0.5V$	15pF	2k Ω	0.3V

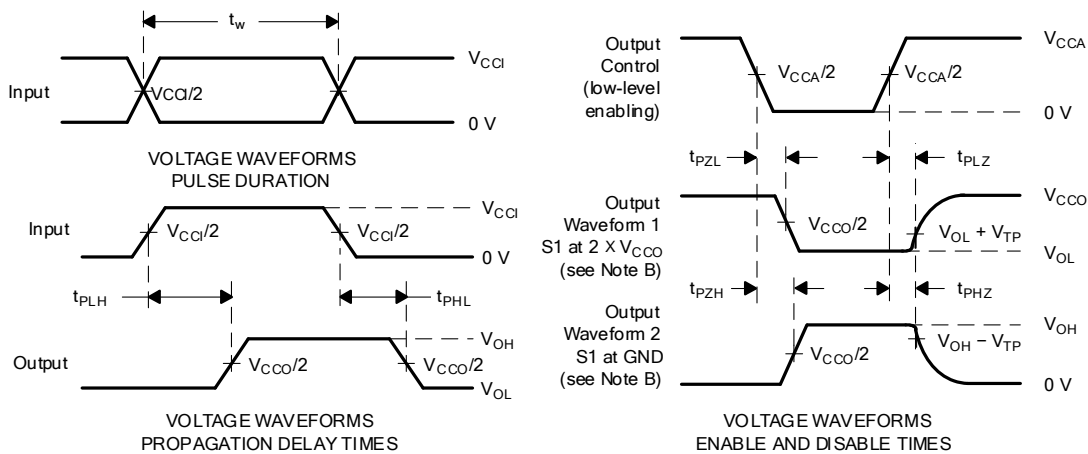

- NOTES: A. C_L includes probe and jig capacitance.
 B. Waveform 1 is for an output with internal conditions such that the output is low, except when disabled by the output control. Waveform 2 is for an output with internal conditions such that the output is high, except when disabled by the output control.
 C. All input pulses are supplied by generators having the following characteristics: $PRR \leq 10$ MHz, $Z_o = 50 \Omega$, $dv/dt \geq 1V/ns$.
 D. The outputs are measured one at a time, with one transition per measurement.
 E. t_{PLZ} and t_{PHZ} are the same as t_{dis} .
 F. t_{PZL} and t_{PZH} are the same as t_{en} .
 G. t_{PLH} and t_{PHL} are the same as t_{pd} .
 H. All parameters and waveforms are not applicable to all devices.

Figure 3. Load Circuit and Voltage Waveforms

10 Application Information

The RS8T245A device can be used in level-translation applications for interfacing devices or systems operating at different interface voltages with one another. The maximum output current can be up to 32 mA when device is powered by 5 V.

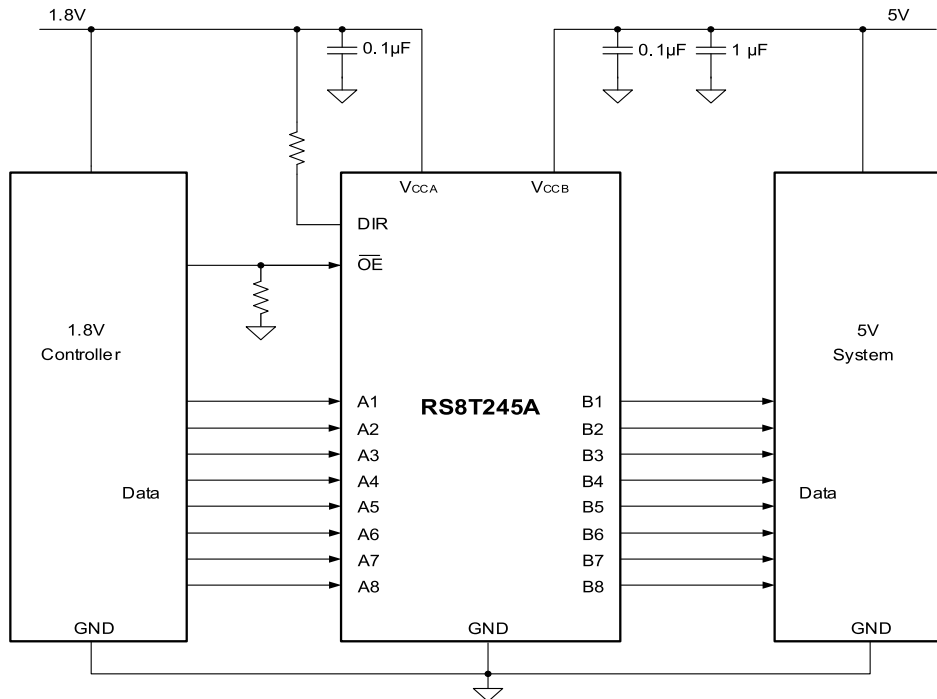
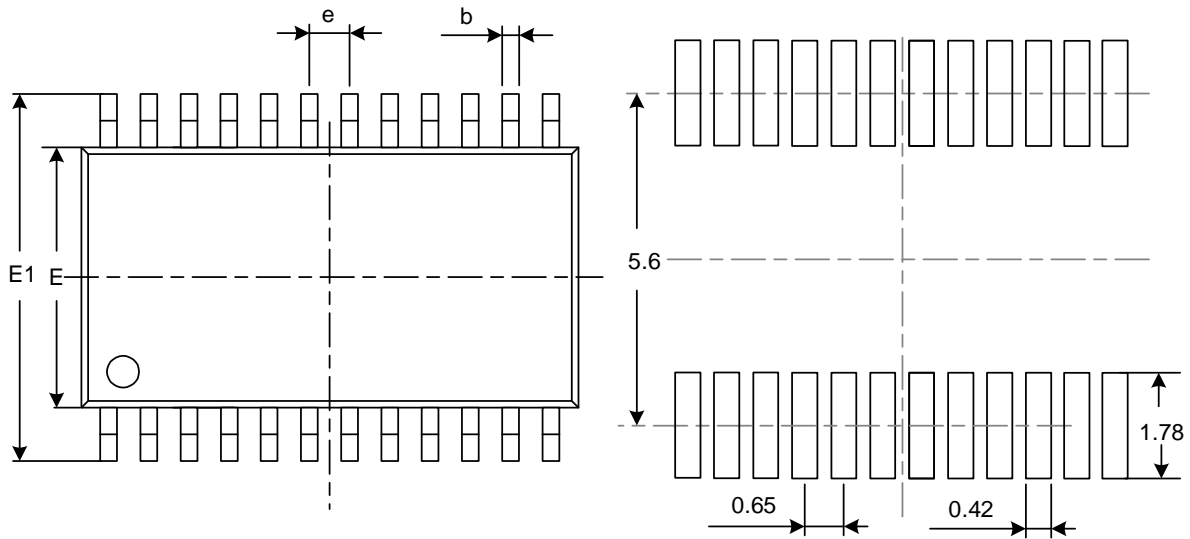

Figure 4. Typical Application Circuit

11 PACKAGE OUTLINE DIMENSIONS

TSSOP-24 (3)



RECOMMENDED LAND PATTERN (Unit: mm)

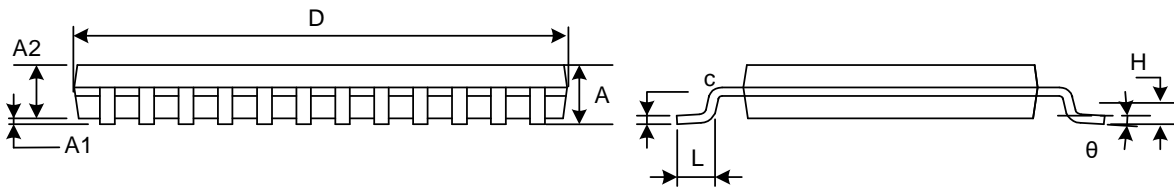

Symbol	Dimensions In Millimeters		Dimensions In Inches	
	Min	Max	Min	Max
A ⁽¹⁾		1.200		0.047
A1	0.050	0.150	0.002	0.006
A2	0.800	1.050	0.031	0.041
b	0.200	0.290	0.008	0.011
c	0.130	0.170	0.005	0.007
D ⁽¹⁾	7.700	7.900	0.303	0.311
E ⁽¹⁾	4.300	4.500	0.169	0.177
E1	6.200	6.600	0.244	0.260
e	0.650 (BSC) ⁽²⁾		0.026 (BSC) ⁽²⁾	
L	0.450	0.750	0.018	0.030
H	0.250 (TYP)		0.010 (TYP)	
θ	0°	8°	0°	8°

NOTE:

1. Plastic or metal protrusions of 0.15mm maximum per side are not included.
2. BSC (Basic Spacing between Centers), "Basic" spacing is nominal.
3. This drawing is subject to change without notice.

12 TAPE AND REEL INFORMATION

REEL DIMENSIONS

TAPE DIMENSION

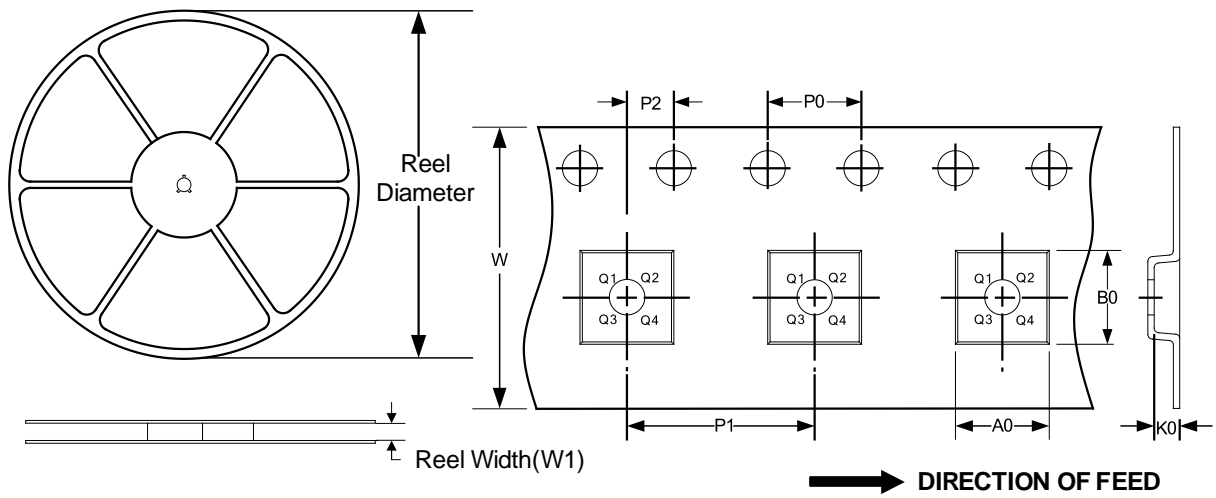

NOTE: The picture is only for reference. Please make the object as the standard.

KEY PARAMETER LIST OF TAPE AND REEL

Package Type	Reel Diameter	Reel Width(mm)	A0 (mm)	B0 (mm)	K0 (mm)	P0 (mm)	P1 (mm)	P2 (mm)	W (mm)	Pin1 Quadrant
TSSOP-24	13"	16.4	6.95	8.30	1.60	4.0	8.0	2.0	16.0	Q1

NOTE:

1. All dimensions are nominal.
2. Plastic or metal protrusions of 0.15mm maximum per side are not included.

IMPORTANT NOTICE AND DISCLAIMER

Jiangsu Runic Technology Co., Ltd. will accurately and reliably provide technical and reliability data (including data sheets), design resources (including reference designs), application or other design advice, WEB tools, safety information and other resources, without warranty of any defect, and will not make any express or implied warranty, including but not limited to the warranty of merchantability Implied warranty that it is suitable for a specific purpose or does not infringe the intellectual property rights of any third party.

These resources are intended for skilled developers designing with Runic products You will be solely responsible for: (1) Selecting the appropriate products for your application; (2) Designing, validating and testing your application; (3) Ensuring your application meets applicable standards and any other safety, security or other requirements; (4) Runic and the Runic logo are registered trademarks of Runic Incorporated. All trademarks are the property of their respective owners; (5) For change details, review the revision history included in any revised document. The resources are subject to change without notice. Our company will not be liable for the use of this product and the infringement of patents or third-party intellectual property rights due to its use.