

# High-Slew Operational Amplifier

## 1 FEATURES

- **Low Offset Voltage:**  $\pm 0.3\text{mV}$  (TYP)
- **Low Offset Voltage Drift:**  $\pm 3.4\mu\text{V}/^\circ\text{C}$
- **High Slew Rate:**  $24\text{V}/\mu\text{s}$  (TYP)
- **High Gain Bandwidth:**  $10\text{MHz}$
- **Output Short-Circuit Protection**
- **Supply Voltage:**  $4.5\text{V}$  to  $32\text{V}$  ( $\pm 2.25\text{V}$  to  $\pm 16\text{V}$ )
- **Extended Temperature:**  $-40^\circ\text{C}$  to  $+125^\circ\text{C}$
- **Micro SIZE PACKAGES:** SOT23-5, SOIC-8(SOP8), SOIC-14(SOP14)

## 2 APPLICATIONS

- **Solar Energy:** String and Central Inverter
- **Motor Drives:** AC and Servo Drive Control and Power Stage Modules
- **Single Phase Online UPS**
- **Three Phase UPS**
- **Pro Audio Mixers**
- **Battery Test Equipment**

## 3 DESCRIPTIONS

The RS846XP family of devices provide outstanding value for cost-sensitive applications, with features including low offset ( $\pm 0.3\text{mV}$ , TYP), high slew rate ( $24\text{V}/\mu\text{s}$ ). Integrated EMI and RF filters, and operation across the full  $-40^\circ\text{C}$  to  $125^\circ\text{C}$  enable the RS846XP devices to be used in the most rugged and demanding applications.

The RS846XP is available in Green SOT23-5, SOIC-8(SOP8), SOIC-14(SOP14) packages. It operates over an ambient temperature range of  $-40^\circ\text{C}$  to  $+125^\circ\text{C}$ .

Device Information <sup>(1)</sup>

PART NUMBER	PACKAGE	BODY SIZE(NOM)
RS8461P	SOT23-5	2.92mmx1.62mm
RS8462P	SOIC-8(SOP8)	4.90mm x 3.90mm
RS8464P	SOIC-14(SOP14)	8.65mm x 3.90mm

(1) For all available packages, see the orderable addendum at the end of the data sheet.

---

## Table of Contents

<b>1 FEATURES</b> .....	1
<b>2 APPLICATIONS</b> .....	1
<b>3 DESCRIPTIONS</b> .....	1
<b>4 Revision History</b> .....	3
<b>5 PACKAGE/ORDERING INFORMATION</b> <sup>(1)</sup> .....	4
<b>6 Pin Configuration and Functions (Top View)</b> .....	5
<b>7 SPECIFICATIONS</b> .....	8
7.1 Absolute Maximum Ratings .....	8
7.2 ESD Ratings .....	8
7.3 Recommended Operating Conditions .....	8
7.4 ELECTRICAL CHARACTERISTICS .....	9
7.5 TYPICAL CHARACTERISTICS .....	11
<b>8 Detailed Description</b> .....	13
8.1 Overview .....	13
8.2 Test Circuit Diagram .....	13
8.3 Power Supply Recommendations .....	13
8.4 Slew Rate .....	13
8.5 Device Functional Modes .....	13
<b>9 Application and Implementation</b> .....	14
9.1 Application Information .....	14
9.2 Inverting Amplifier Application .....	14
<b>10 LAYOUT</b> .....	15
10.1 Layout Guidelines .....	15
10.2 Layout Example .....	15
<b>11 PACKAGE OUTLINE DIMENSIONS</b> .....	16
<b>12 TAPE AND REEL INFORMATION</b> .....	19

## 4 Revision History

Note: Page numbers for previous revisions may differ from page numbers in the current version.

Version	Change Date	Change Item
A.1	2022/10/20	Initial version completed
A.2	2023/06/07	Add RS8461PXF Orderable Device

**5 PACKAGE/ORDERING INFORMATION <sup>(1)</sup>**

Orderable Device	Package Type	Pin	Channel	Op Temp(°C)	Eco Plan <sup>(2)</sup>	Lead finish/Ball material <sup>(3)</sup>	MSL-Peak Temp <sup>(4)</sup>	Device Marking <sup>(5)</sup>	Package Qty
RS8461PXF	SOT23-5	5	1	-40°C ~125°C	RoHS & Green	Sn	Level-3-260°C-1 WEEK	8461P	Tape and Reel,3000
RS8462PXK	SOIC-8 (SOP8)	8	2	-40°C ~125°C	RoHS & Green	Sn	Level-3-260°C-1 WEEK	RS8462P	Tape and Reel,4000
RS8464PXP	SOIC-14 (SOP14)	14	4	-40°C ~125°C	RoHS & Green	Sn	Level-3-260°C-1 WEEK	RS8464P	Tape and Reel,4000

**NOTE:**

- (1) This information is the most current data available for the designated devices. This data is subject to change without notice and revision of this document. For browser-based versions of this data sheet, refer to the right-hand navigation.
- (2) **RoHS:** Runic defines "RoHS" to mean semiconductor products that are compliant with the current EU RoHS requirements for all 10 RoHS substances, including the requirement that RoHS substance do not exceed 0.1% by weight in homogeneous materials. Where designed to be soldered at high temperatures, "RoHS" products are suitable for use in specified lead-free processes. Runic may reference these types of products as "Pb-Free".  
**RoHS Exempt:** Runic defines "RoHS Exempt" to mean products that contain lead but are compliant with EU RoHS pursuant to a specific EU RoHS exemption.  
**Green:** Runic defines "Green" to mean the content of Chlorine (Cl) and Bromine (Br) based flame retardants meet JS709B low halogen requirements of <=1000ppm threshold. Antimony trioxide-based flame retardants must also meet the <=1000ppm threshold requirement.
- (3) Lead finish/Ball material. Orderable Devices may have multiple material finish options. Finish options are separated by a vertical ruled line. Lead finish/Ball material values may wrap to two lines if the finish value exceeds the maximum column width.
- (4) MSL-Peak Temp. The Moisture Sensitivity Level rating according to the JEDEC industry standard classifications, and peak solder temperature.
- (5) There may be additional marking, which relates to the lot trace code information(data code and vendor code), the logo or the environmental category on the device.

## 6 Pin Configuration and Functions (Top View)

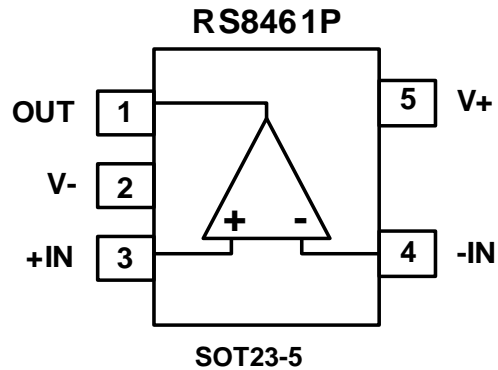

### Pin Description

NAME	PIN		I/O <sup>(1)</sup>	DESCRIPTION
	RS8461P			
	SOT23-5			
-IN	4	I	Negative (inverting) input	
+IN	3	I	Positive (noninverting) input	
OUT	1	O	Output	
V-	2	-	Negative (lowest) power supply	
V+	5	-	Positive (highest) power supply	

(1) I = Input, O = Output.

## Pin Configuration and Functions (Top View)

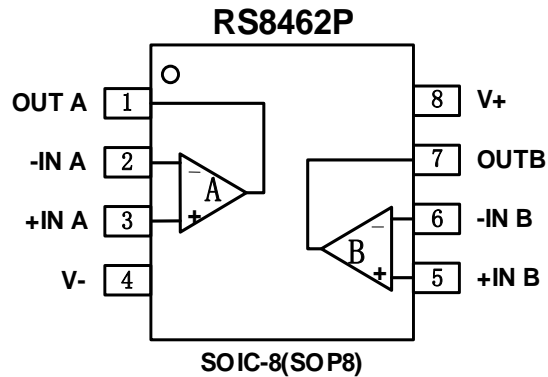

### Pin Description

NAME	PIN	I/O <sup>(1)</sup>	DESCRIPTION
	SOIC-8(SOP8)		
-INA	2	I	Inverting input, channel A
+INA	3	I	Noninverting input, channel A
-INB	6	I	Inverting input, channel B
+INB	5	I	Noninverting input, channel B
OUTA	1	O	Output, channel A
OUTB	7	O	Output, channel B
V-	4	-	Negative (lowest) power supply or ground (for single supply operation)
V+	8	-	Positive (highest) power supply

(1) I = Input, O = Output.

## Pin Configuration and Functions (Top View)

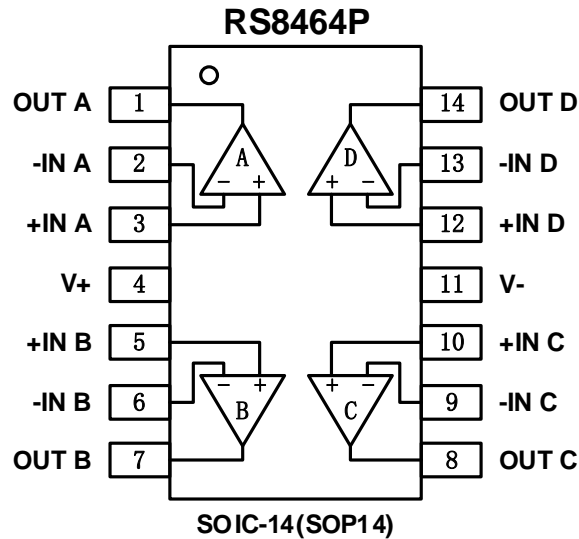

### Pin Description

NAME	PIN	I/O <sup>(1)</sup>	DESCRIPTION
	SOIC-14(SOP14)		
-INA	2	I	Inverting input, channel A
+INA	3	I	Noninverting input, channel A
-INB	6	I	Inverting input, channel B
+INB	5	I	Noninverting input, channel B
-INC	9	I	Inverting input, channel C
+INC	10	I	Noninverting input, channel C
-IND	13	I	Inverting input, channel D
+IND	12	I	Noninverting input, channel D
OUTA	1	O	Output, channel A
OUTB	7	O	Output, channel B
OUTC	8	O	Output, channel C
OUTD	14	O	Output, channel D
V-	11	-	Negative (lowest) power supply or ground (for single supply operation)
V+	4	-	Positive (highest) power supply

(1) I = Input, O = Output.

## 7 SPECIFICATIONS

### 7.1 Absolute Maximum Ratings

Over operating free-air temperature range (unless otherwise noted) <sup>(1)</sup>

		MIN	MAX	UNIT
Voltage	Supply, $V_S = (V+) - (V-)$		36	V
	Signal input pin <sup>(2)</sup>	(V-)-0.5	(V+) +0.5	
Current	Signal input pin <sup>(2)</sup>	-10	10	mA
	Output short-circuits <sup>(3)</sup>	Continuous		
$\theta_{JA}$	Package thermal impedance <sup>(4)</sup>	SOT23-5	230	°C/W
		SOIC-8(SOP8)	110	
		SOIC-14(SOP14)	105	
Temperature	Operating range, $T_A$	-40	125	°C
	Junction, $T_J$ <sup>(5)</sup>	-40	150	
	Storage, $T_{stg}$	-65	150	

(1) Stresses above these ratings may cause permanent damage. Exposure to absolute maximum conditions for extended periods may degrade device reliability. These are stress ratings only, and functional operation of the device at these or any other conditions beyond those specified is not implied.

(2) Input terminals are diode-clamped to the power-supply rails. Input signals that can swing more than 0.5V beyond the supply rails should be current-limited to 10mA or less.

(3) Short-circuit to ground, one amplifier per package.

(4) The package thermal impedance is calculated in accordance with JESD-51.

(5) The maximum power dissipation is a function of  $T_{J(MAX)}$ ,  $R_{\theta JA}$ , and  $T_A$ . The maximum allowable power dissipation at any ambient temperature is  $P_D = (T_{J(MAX)} - T_A) / R_{\theta JA}$ . All numbers apply for packages soldered directly onto a PCB.

### 7.2 ESD Ratings

The following ESD information is provided for handling of ESD-sensitive devices in an ESD protected area only.

		VALUE	LEVEL	UNIT	
$V_{(ESD)}$	Electrostatic discharge	Human-body model (HBM), per ANSI/ESDA/JEDEC JS-001 <sup>(1)</sup>	±2000	2	V
		Charged-device model (CDM), per ANSI/ESDA/JEDEC JS-002 <sup>(2)</sup>	±1500	3	
		Machine Model (MM)	±200	3	

(1) JEDEC document JEP155 states that 500 V HBM allows safe manufacturing with a standard ESD control process.

(2) JEDEC document JEP157 states that 250 V CDM allows safe manufacturing with a standard ESD control process.



### ESD SENSITIVITY CAUTION

ESD damage can range from subtle performance degradation to complete device failure. Precision integrated circuits may be more susceptible to damage because very small parametric changes could cause the device not to meet its published specifications.

### 7.3 Recommended Operating Conditions

Over operating free-air temperature range (unless otherwise noted)

		MIN	NOM	MAX	UNIT
Supply voltage, $V_S = (V+) - (V-)$	Single-supply	4.5		32	V
	Dual-supply	±2.25		±16	
Operating range, $T_A$		-40		125	°C



## 7.4 ELECTRICAL CHARACTERISTICS

(At  $T_A=+25^{\circ}\text{C}$ ,  $V_S=4.5\text{V}$  to  $32\text{V}$  ( $\pm 2.25\text{V}$  to  $\pm 16\text{V}$ ),  $R_L=10\text{k}\Omega$  connected to  $V_S/2$ ,  $V_{CM}=V_S/2$  and  $V_{OUT}=V_S/2$ , Full <sup>(9)</sup>  $=-40^{\circ}\text{C}$  to  $+125^{\circ}\text{C}$ , unless otherwise noted.) <sup>(1)</sup>

PARAMETER	SYMBOL	CONDITION	TEMP	MIN <sup>(2)</sup>	TYP <sup>(3)</sup>	MAX <sup>(2)</sup>	UNIT
<b>INPUT CHARACTERISTICS</b>							
Input Offset Voltage	$V_{OS}$	$V_S=\pm 16\text{V}$ , $V_{CM}=V_S/2$	+25°C	-1	$\pm 0.3$	1	mV
			FULL		$\pm 0.36$		
Input Offset Voltage Average Drift	$V_{OS} T_c$		FULL		$\pm 3.4$		$\mu\text{V}/^{\circ}\text{C}$
Input Bias Current <sup>(4) (5)</sup>	$I_B$		+25°C		$\pm 10$	$\pm 60$	$\mu\text{A}$
			FULL		$\pm 600$		$\mu\text{A}$
Input Offset Current <sup>(4)</sup>	$I_{OS}$		+25°C		$\pm 10$	$\pm 60$	$\mu\text{A}$
			FULL		$\pm 600$		$\mu\text{A}$
Power-Supply Rejection Ratio	PSRR	$V_S=5\text{V}\sim 32\text{V}$ , $V_{CM}=V_S/2$	+25°C	89	101		dB
			FULL		100		
Input Common-Mode Voltage Range	$V_{CM}$		FULL	(V-)		(V+)-2	V
Common-Mode Rejection Ratio	CMRR	$V_S=32\text{V}$ , (V-) $< V_{CM} < (V+)-2\text{V}$	+25°C	94	110		dB
			FULL		108		
Open-Loop Voltage Gain	$A_{OL}$	$V_S=32\text{V}$ , $R_L=10\text{K}\Omega$ $V_O=(V-)+0.5\text{V}$ to $(V+)-0.5\text{V}$	+25°C	101	124		dB
			FULL		117		
<b>NOISE PERFORMANCE</b>							
Input Voltage Noise	$e_{n\text{-p-p}}$	$f=0.1\text{Hz}$ to $10\text{Hz}$	+25°C		8.5		$\mu\text{V}_{PP}$
Input Voltage Noise Density <sup>(4)</sup>	$e_n$	$f=1\text{KHz}$	+25°C		40		$\text{nV}/\sqrt{\text{Hz}}$
<b>DYNAMIC PERFORMANCE</b>							
Slew Rate <sup>(8)</sup>	SR	$G=+1$ , $V_S=32\text{V}$	+25°C		24		$\text{V}/\mu\text{s}$
Settling Time to 0.1%	$t_s$	$V_S=32\text{V}$ , $V_{PP}=7\text{V}$ , $G=+1$ $C_L=100\text{pF}$	+25°C		1.2		$\mu\text{s}$
Gain-Bandwidth Product	GBP	$V_S=32\text{V}$ , $V_{IN}=50\text{mV}_{P-P}$	+25°C		10		MHz
Overload Recovery Time	$t_{OR}$	$V_{IN} \times G \geq V_S$	+25°C		0.35		$\mu\text{s}$
Phase Margin <sup>(4)</sup>	$\phi_O$	$V_{OUT}=100\text{mV}_{P-P}$ , $C_L=70\text{pF}$	+25°C		60		$^{\circ}$
<b>OUTPUT CHARACTERISTICS</b>							
Output Voltage Swing from Rail	$V_{OH}$	$V_S=\pm 16\text{V}$ , $R_L=10\text{K}\Omega$	+25°C		90	150	mV
	$V_{OL}$		+25°C		65	150	
Output Source Current <sup>(6) (7)</sup>	$I_{SOURCE}$	$V_S=32\text{V}$	+25°C	40	75		mA
Output Sink Current <sup>(6) (7)</sup>	$I_{SINK}$			40	75		
<b>POWER SUPPLY</b>							
Operating Voltage Range	$V_S$		FULL	4.5		32	V
Quiescent Current/ Amplifier	$I_Q$	$V_S=\pm 2.5\text{V}$ , $I_{OUT}=0\text{mA}$	+25°C		2.2	4.1	mA
			FULL			4.5	
		$V_S=\pm 16\text{V}$ , $I_{OUT}=0\text{mA}$	+25°C		2.6	4.6	
			FULL			5.0	
Turn-On Time		$V_S=32\text{V}$	+25°C		52		$\mu\text{s}$

**NOTE:**

- (1) Electrical table values apply only for factory testing conditions at the temperature indicated. Factory testing conditions result in very limited self-heating of the device.
- (2) Limits are 100% production tested at 25°C. Limits over the operating temperature range are ensured through correlations using statistical quality control (SQC) method.
- (3) Typical values represent the most likely parametric norm as determined at the time of characterization. Actual typical values may vary over time and will also depend on the application and configuration.
- (4) This parameter is ensured by design and/or characterization and is not tested in production.
- (5) Positive current corresponds to current flowing into the device.
- (6) The maximum power dissipation is a function of  $T_{J(MAX)}$ ,  $R_{\theta JA}$ , and  $T_A$ . The maximum allowable power dissipation at any ambient temperature is  $PD = (T_{J(MAX)} - T_A) / R_{\theta JA}$ . All numbers apply for packages soldered directly onto a PCB.
- (7) Short circuit test is a momentary test.
- (8) Number specified is the slower of positive and negative slew rates.
- (9) Specified by characterization only.

## 7.5 TYPICAL CHARACTERISTICS

NOTE: The graphs and tables provided following this note are a statistical summary based on a limited number of samples and are provided for informational purposes only.

At  $T_A = +25^\circ\text{C}$ ,  $V_S = \pm 16\text{V}$ , unless otherwise noted.

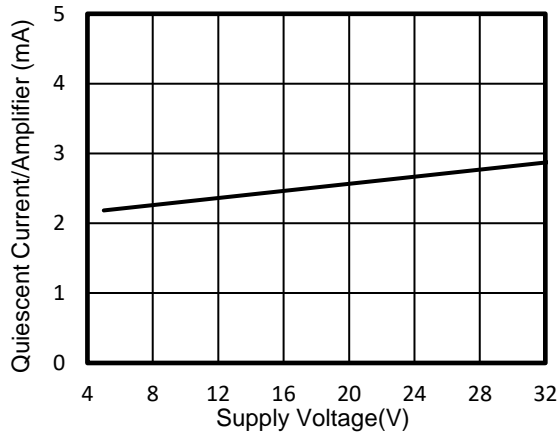

Figure 1. Supply Voltage vs Quiescent Current

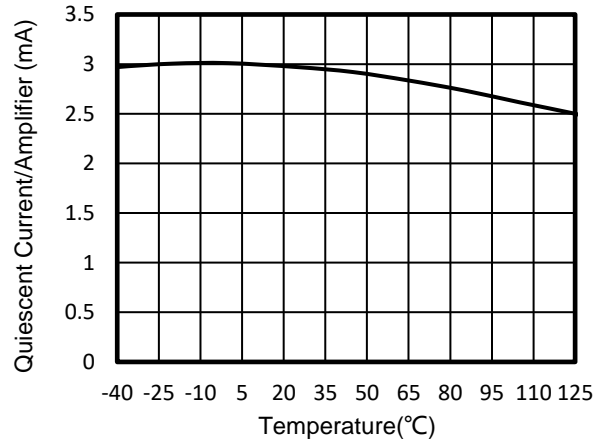

Figure 2. Quiescent Current vs Temperature

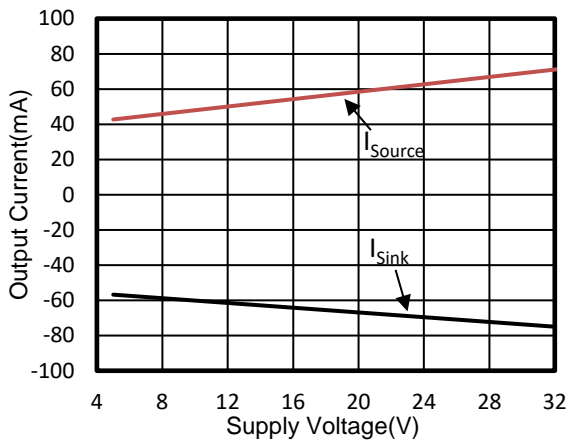

Figure 3. Supply Voltage vs Output Current

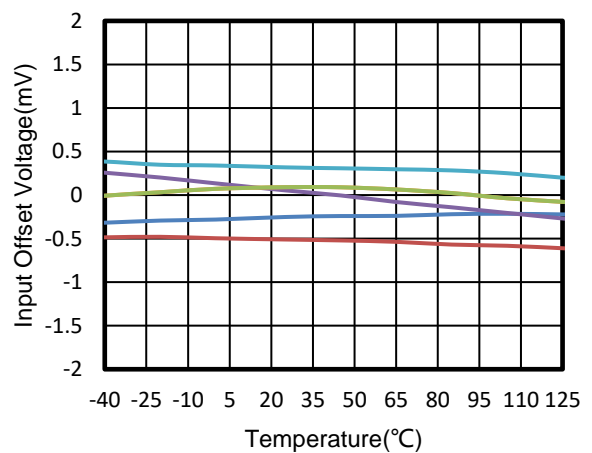

Figure 4. Input Offset Voltage vs Temperature

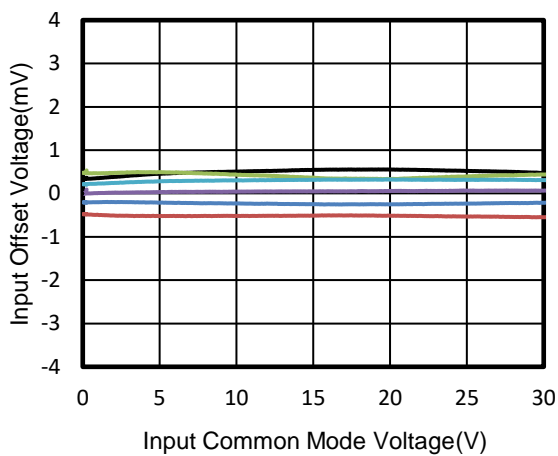

Figure 5. Input Offset Voltage vs Input Common Mode Voltage

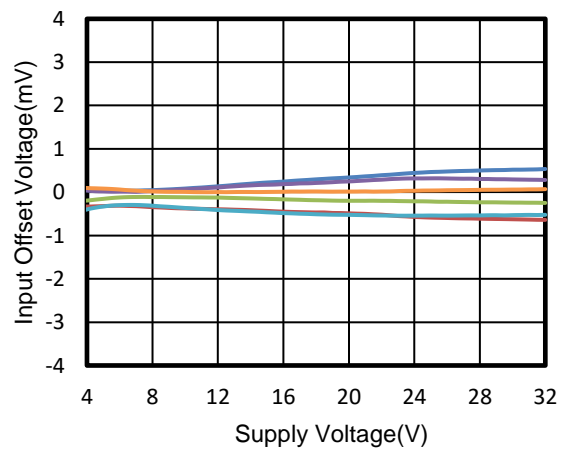

Figure 6. Input Offset Voltage vs Supply Voltage

## TYPICAL CHARACTERISTICS

NOTE: The graphs and tables provided following this note are a statistical summary based on a limited number of samples and are provided for informational purposes only.

At  $T_A = +25^\circ\text{C}$ ,  $V_S = \pm 16\text{V}$ , unless otherwise noted.

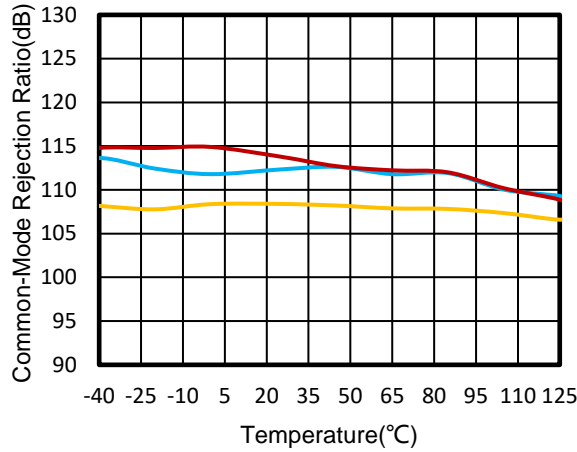

Figure 7. Common-Mode Rejection Ratio vs Temperature

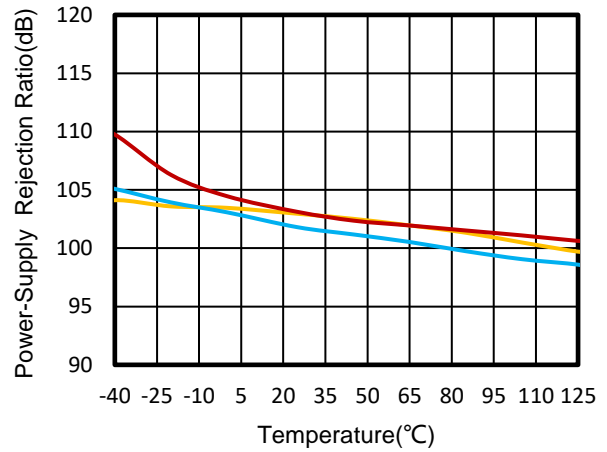

Figure 8. Power-Supply Rejection Ratio vs Temperature

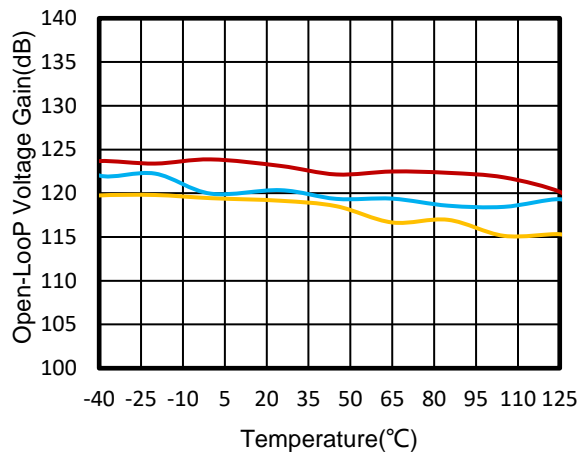

Figure 9. Open-Loop Voltage Gain vs Temperature

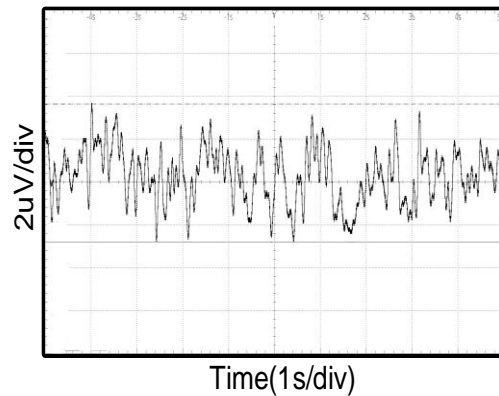

Figure 10. 0.1-Hz to 10-Hz Noise

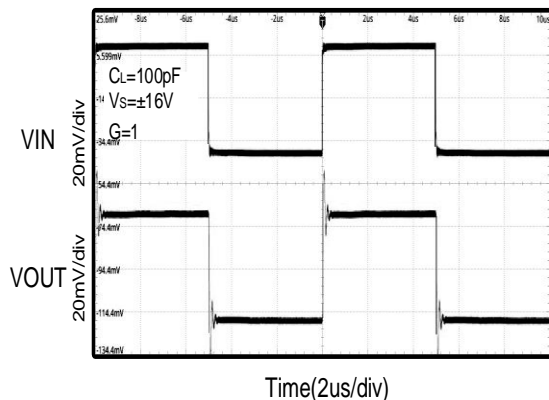

Figure 11. Small-Signal Step Response

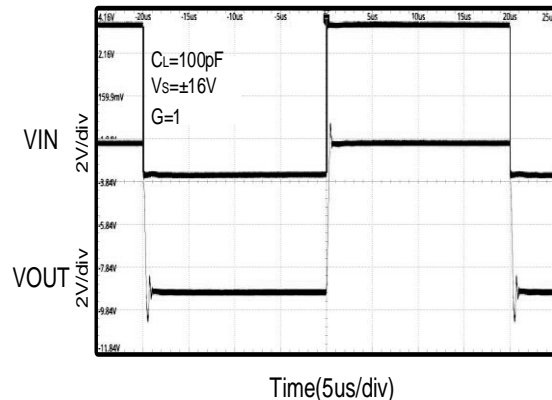

Figure 12. Large-Signal Step Response

## 8 Detailed Description

### 8.1 Overview

The RS846XP is the next-generation family of the industry standard RS845X high-voltage general purpose amplifiers. These devices provide outstanding value for cost-sensitive applications requiring high slew rate with high voltage signals, such as motor drive and inverter systems.

A robust MUX-friendly input stage enhances flexibility in design, with common-mode voltage range extending to the negative rail as well as improved settling time in multi-channel applications. Low offset voltage ( $\pm 0.3\text{mV}$ , TYP) and low offset voltage drift ( $\pm 3.4\mu\text{V}/^\circ\text{C}$ ) allows the RS846XP family to be used in rugged applications requiring precision current and voltage sensing. High voltage operation (up to 36 V) and high slew rate ( $24\text{V}/\mu\text{s}$ ) make the RS846XP family a premier choice for high-voltage applications with fast transients.

### 8.2 Test Circuit Diagram

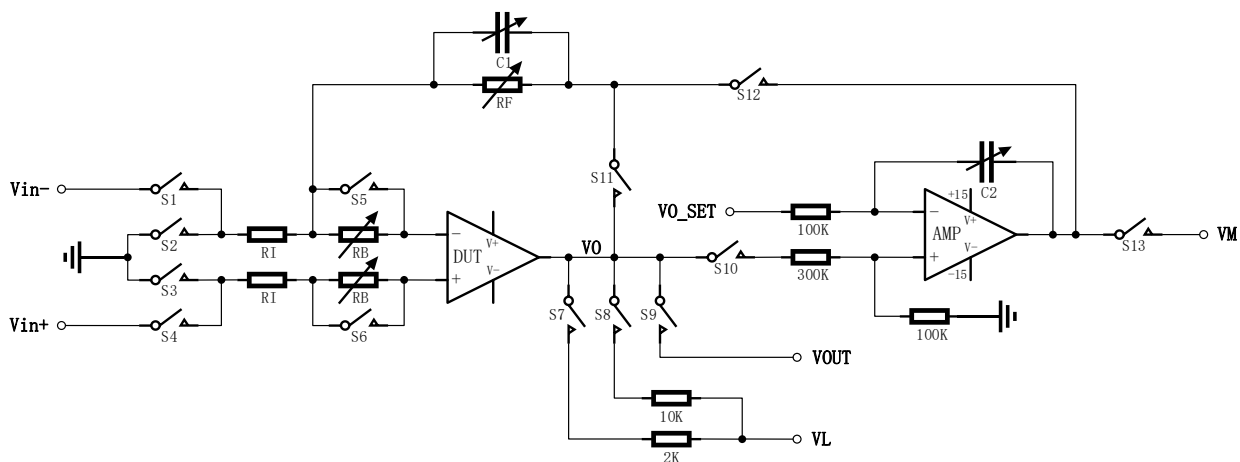

**NOTE:**

1. The device under test has a default power supply of plus or minus 104 capacitors to GND.
2.  $\pm 15\text{V}$  power supply was used for auxiliary operational amplifier.
3. The loop stability can be adjusted by adjusting the capacitance of C1 and C2, which are 101~102 for C1 and 102~104 for C2.

### 8.3 Power Supply Recommendations

Supply voltages larger than 32 V for a single-supply or outside the range of  $\pm 16\text{V}$  for a dual-supply can permanently damage the device. Place  $0.1\mu\text{F}$  bypass capacitors close to the power-supply pins to reduce errors coupling in from noisy or high impedance power supplies.

### 8.4 Slew Rate

The slew rate is the rate at which an operational amplifier can change its output when there is a change on the input. These devices have a  $24\text{V}/\mu\text{s}$  slew rate.

### 8.5 Device Functional Modes

These devices are powered on when the supply is connected. This device can be operated as a single-supply operational amplifier or dual-supply amplifier depending on the application.

## 9 Application and Implementation

Information in the following applications sections is not part of the RUNIC component specification, and RUNIC does not warrant its accuracy or completeness. RUNIC's customers are responsible for determining suitability of components for their purposes. Customers should validate and test their design implementation to confirm system functionality.

### 9.1 Application Information

The RS846XP series of operational amplifiers can be used in countless applications. The few applications in this section show principles used in all applications of these parts.

### 9.2 Inverting Amplifier Application

A typical application for an operational amplifier in an inverting amplifier. This amplifier takes a positive voltage on the input, and makes it a negative voltage of the same magnitude. In the same manner, it also makes negative voltages positive.

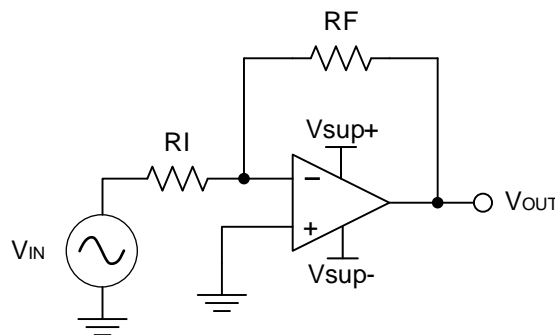

**Figure 13. Schematic for Inverting Amplifier Application**

## 10 LAYOUTS

### 10.1 Layout Guidelines

For best operational performance of the device, use good PCB layout practices, including:

- Noise can propagate into analog circuitry through the power pins of the circuit as a whole and operational amplifier itself. Bypass capacitors are used to reduce the coupled noise by providing low-impedance power sources local to the analog circuitry.
  - Connect low-ESR, 0.1 $\mu$ F ceramic bypass capacitors between each supply pin and ground, placed as close to the device as possible. A single bypass capacitor from V+ to ground is applicable for single supply applications.
- Separate grounding for analog and digital portions of circuitry is one of the simplest and most-effective methods of noise suppression. One or more layers on multilayer PCBs are usually devoted to ground planes. A ground plane helps distribute heat and reduces EMI noise pickup. Make sure to physically separate digital and analog grounds paying attention to the flow of the ground current.
- To reduce parasitic coupling, run the input traces as far away from the supply or output traces as possible. If these traces cannot be kept separate, crossing the sensitive trace perpendicular is much better as opposed to in parallel with the noisy trace.
- Place the external components as close to the device as possible. As shown in Figure 15, keeping RF and RG close to the inverting input minimizes parasitic capacitance.
- Keep the length of input traces as short as possible. Always remember that the input traces are the most sensitive part of the circuit.
- Consider a driven, low-impedance guard ring around the critical traces. A guard ring can significantly reduce leakage currents from nearby traces that are at different potentials.

### 10.2 Layout Example

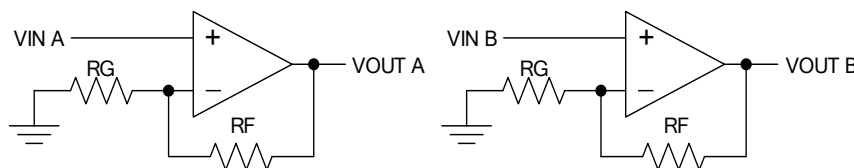

**Figure 14. Schematic Representation**

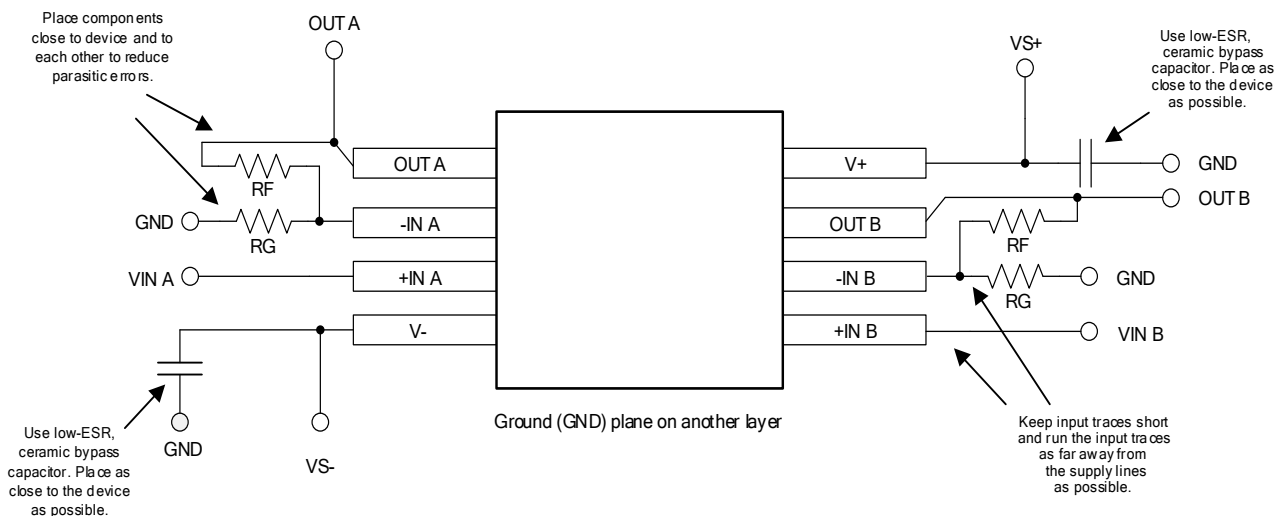
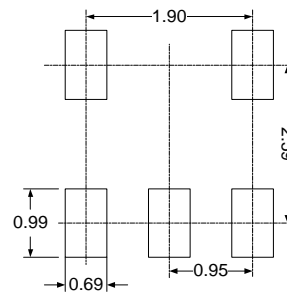
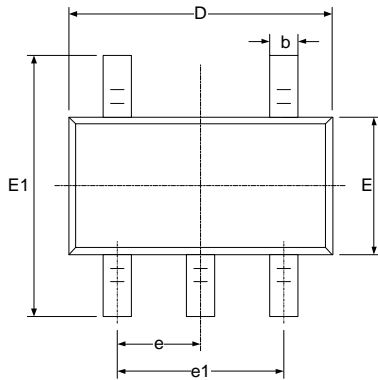

**Figure 15. Layout Recommendation**

NOTE: Layout Recommendations have been shown for dual op-amp only, follow similar precautions for Single and four.

# 11 PACKAGE OUTLINE DIMENSIONS

## SOT23-5



**RECOMMENDED LAND PATTERN (Unit: mm)**

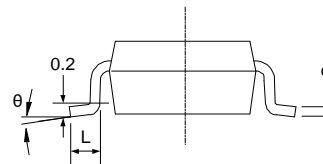
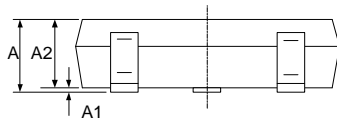

Symbol	Dimensions In Millimeters		Dimensions In Inches	
	Min	Max	Min	Max
A	1.050	1.250	0.041	0.049
A1	0.000	0.100	0.000	0.004
A2	1.050	1.150	0.041	0.045
b	0.300	0.500	0.012	0.020
c	0.100	0.200	0.004	0.008
D	2.820	3.020	0.111	0.119
E	1.500	1.700	0.059	0.067
E1	2.650	2.950	0.104	0.116
e	0.950(BSC)		0.037(BSC)	
e1	1.800	2.000	0.071	0.079
L	0.300	0.600	0.012	0.024
$\theta$	0°	8°	0°	8°

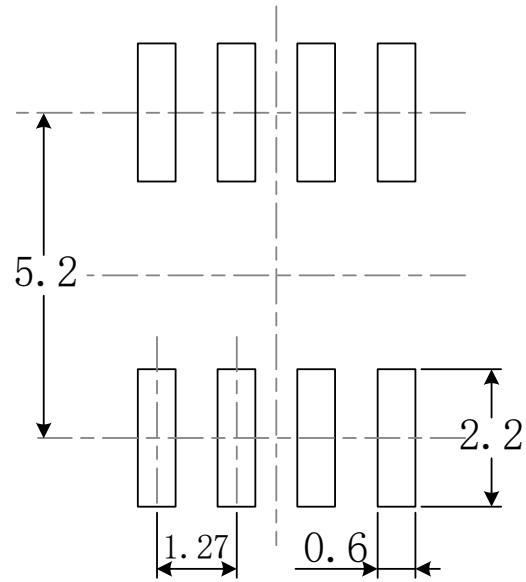
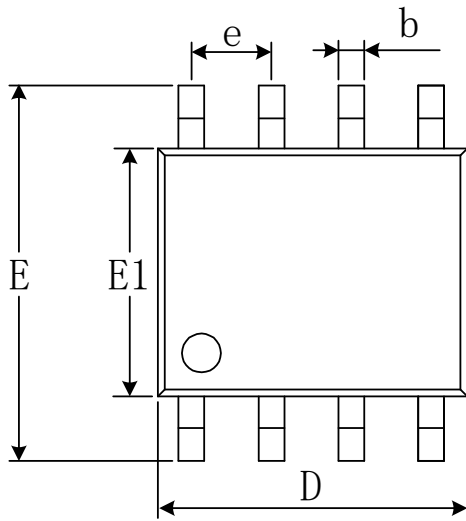
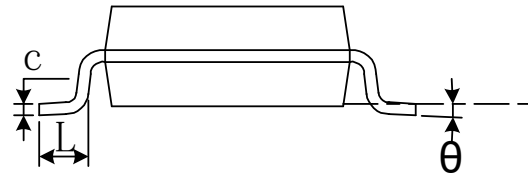
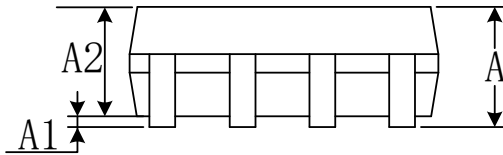

**SOIC-8(SOP8)**

**RECOMMENDED LAND PATTERN** (Unit: mm)

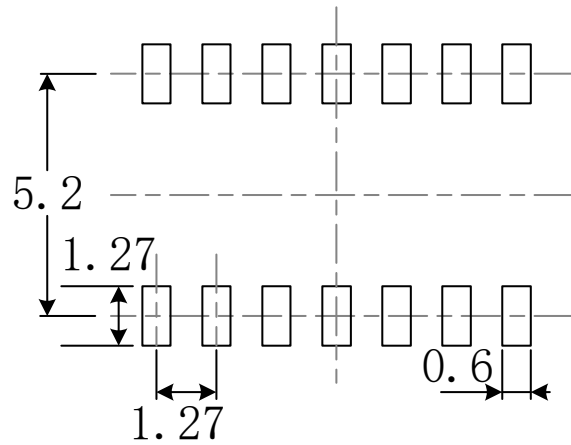
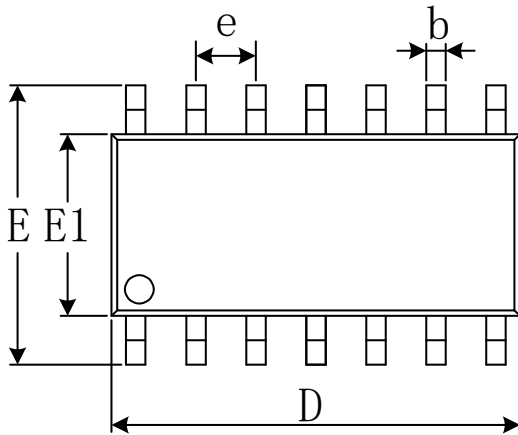
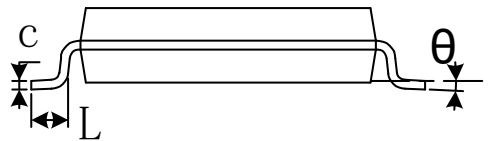
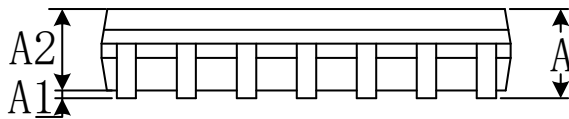
Symbol	Dimensions In Millimeters		Dimensions In Inches	
	Min	Max	Min	Max
A	1.350	1.750	0.053	0.069
A1	0.100	0.250	0.004	0.010
A2	1.350	1.550	0.053	0.061
b	0.330	0.510	0.013	0.020
c	0.170	0.250	0.007	0.010
D	4.800	5.000	0.189	0.197
e	1.270(BSC)		0.050(BSC)	
E	5.800	6.200	0.228	0.244
E1	3.800	4.000	0.150	0.157
L	0.400	1.270	0.016	0.050
$\theta$	0°	8°	0°	8°

**SOIC-14(SOP14)**

**RECOMMENDED LAND PATTERN (Unit: mm)**

Symbol	Dimensions In Millimeters		Dimensions In Inches	
	Min	Max	Min	Max
A	1.350	1.750	0.053	0.069
A1	0.100	0.250	0.004	0.010
A2	1.350	1.550	0.053	0.061
b	0.310	0.510	0.012	0.020
c	0.100	0.250	0.004	0.010
D	8.450	8.850	0.333	0.348
e	1.270(BSC)		0.050(BSC)	
E	5.800	6.200	0.228	0.244
E1	3.800	4.000	0.150	0.157
L	0.400	1.270	0.016	0.050
$\theta$	0°	8°	0°	8°

**NOTE:**

- A. All linear dimension is in millimeters.
- B. This drawing is subject to change without notice.
- C. Body dimensions do not include mold flash or protrusion. Mold flash and protrusion shall not exceed 0.15 per side.
- D. BSC: Basic Dimension. Theoretically exact value shown without tolerances.

## 12 TAPE AND REEL INFORMATION

### REEL DIMENSIONS

### TAPE DIMENSION

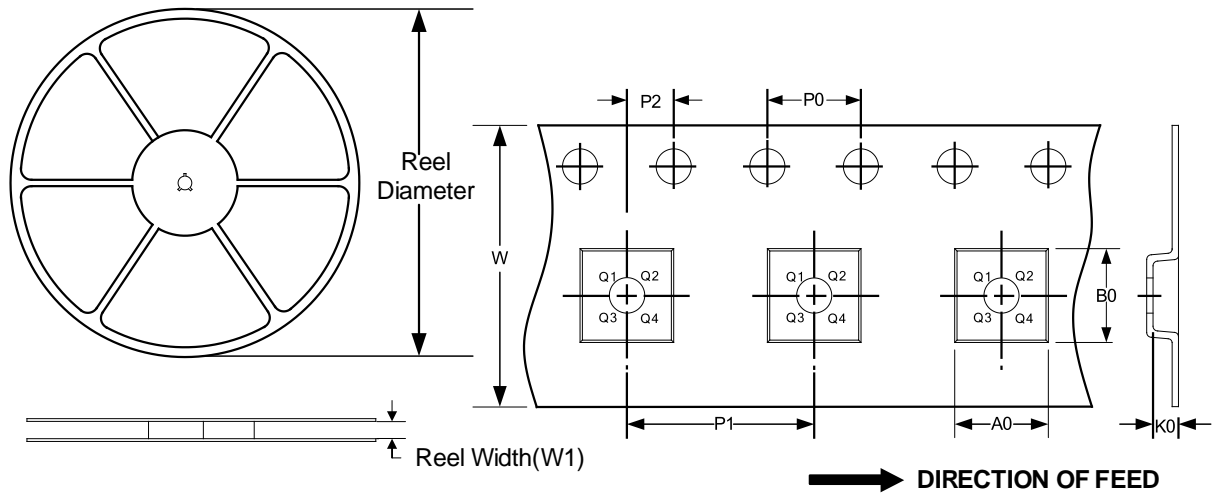

NOTE: The picture is only for reference. Please make the object as the standard.

### KEY PARAMETER LIST OF TAPE AND REEL

Package Type	Reel Diameter	Reel Width W1(mm)	A0 (mm)	B0 (mm)	K0 (mm)	P0 (mm)	P1 (mm)	P2 (mm)	W (mm)	Pin1 Quadrant
SOT23-5	7"	9.5	3.20	3.20	1.40	4.0	4.0	2.0	8.0	Q3
SOIC-8(SOP8)	13"	12.4	6.40	5.40	2.10	4.0	8.0	2.0	12.0	Q1
SOIC-14(SOP14)	13"	16.4	6.60	9.30	2.10	4.0	8.0	2.0	16.0	Q1

NOTE:

1. All dimensions are nominal.
2. Plastic or metal protrusions of 0.15mm maximum per side are not included.

---

## **IMPORTANT NOTICE AND DISCLAIMER**

Jiangsu Runic Technology Co., Ltd. will accurately and reliably provide technical and reliability data (including data sheets), design resources (including reference designs), application or other design advice, WEB tools, safety information and other resources, without warranty of any defect, and will not make any express or implied warranty, including but not limited to the warranty of merchantability Implied warranty that it is suitable for a specific purpose or does not infringe the intellectual property rights of any third party.

These resources are intended for skilled developers designing with Runic products You will be solely responsible for: (1) Selecting the appropriate products for your application; (2) Designing, validating and testing your application; (3) Ensuring your application meets applicable standards and any other safety, security or other requirements; (4) Runic and the Runic logo are registered trademarks of Runic Incorporated. All trademarks are the property of their respective owners; (5) For change details, review the revision history included in any revised document. The resources are subject to change without notice. Our company will not be liable for the use of this product and the infringement of patents or third-party intellectual property rights due to its use.