

RS138T 3-Line to 8-Line Decoders/Demultiplexers Inverting and Noninverting

1 FEATURES

- **Operating Voltage Range: 4.5V to 5.5V**
- **Low Power Consumption: 160μA (Max)**
- **I/O Port or Memory Selector**
- **Three Enable Inputs to Simplify Cascading**
- **Balanced Propagation Delay and Transition Times**
- **Operating Temperature Range: -40°C to +125°C**
- **Inputs Accept Voltage to 5.5V**
- **Inputs are TTL-Voltage compatible**
- **Micro SIZE PACKAGES: SOIC-16(SOP16), TSSOP-16**

2 APPLICATIONS

- **LED Displays**
- **Servers**
- **White Goods**
- **Power Infrastructure**
- **Factory Automation**

3 DESCRIPTIONS

The RS138T, a three to eight decoders/demultiplexers, is designed for 4.5V to 5.5V V_{CC} operation.

The RS138T is consist of three enable inputs ($E3, \bar{E}2$ and $\bar{E}1$), three binary weighted address inputs ($A0, A1$ and $A2$) and eight outputs ($\bar{Y}0$ to $\bar{Y}7$). Among all enable inputs, one is active high output enable ($E3$) and two are active low output enables ($\bar{E}2$ and $\bar{E}1$). When the outputs are gated by any of the strobe inputs, they are all forced into the high state. When the outputs are not disabled by the strobe inputs, only the selected output is low while all others are high.

The RS138T is available in Green SOIC-16(SOP16) and TSSOP-16 packages. It operates over an ambient temperature range of -40°C to +125°C.

Device Information ⁽¹⁾

PART NUMBER	PACKAGE	BODY SIZE (NOM)
RS138T	SOIC-16 (SOP16)	9.90mm×3.91mm
	TSSOP-16	5.00mm×4.40mm

(1) For all available packages, see the orderable addendum at the end of the data sheet.

Table of Contents

1 FEATURES	1
2 APPLICATIONS	1
3 DESCRIPTIONS	1
4 Revision History	3
5 PACKAGE/ORDERING INFORMATION ⁽¹⁾	4
6 PIN CONFIGURATIONS	5
7 SPECIFICATIONS	6
7.1 Absolute Maximum Ratings ⁽¹⁾	6
7.2 ESD Ratings	6
7.3 Recommended Operating Conditions	7
7.4 ELECTRICAL CHARACTERISTICS	7
7.5 Switching Characteristics	8
8 Parameter Measurement Information	9
9 Detailed Description	10
9.1 Overview	10
9.2 Functional Block Diagram	10
9.3 Device Functional Modes	11
10 Power Supply Recommendations	12
11 Layout	12
11.1 Layout Guidelines	12
11.2 Layout Example	12
12 PACKAGE OUTLINE DIMENSIONS	13
13 TAPE AND REEL INFORMATION	15

4 Revision History

Note: Page numbers for previous revisions may differ from page numbers in the current version.

Version	Change Date	Change Item
A.1	2023/05/09	Initial version completed

5 PACKAGE/ORDERING INFORMATION (1)

PRODUCT	ORDERING NUMBER	TEMPERATURE RANGE	PACKAGE LEAD	PACKAGE MARKING (2)	MSL(3)	PACKAGE OPTION
RS138T	RS138TXS16	-40°C ~+125°C	SOIC-16 (SOP16)	RS138T	MSL3	Tape and Reel,4000
	RS138TXS16-G	-40°C ~+125°C	SOIC-16 (SOP16)	RS138T	MSL1	Tape and Reel,4000
	RS138TXTSS16-G	-40°C ~+125°C	TSSOP-16	RS138T	MSL1	Tape and Reel,4000

NOTE:

- (1) This information is the most current data available for the designated devices. This data is subject to change without notice and revision of this document. For browser-based versions of this data sheet, refer to the right-hand navigation.
- (2) There may be additional marking, which relates to the lot trace code information (data code and vendor code), the logo or the environmental category on the device.
- (3) MSL, The Moisture Sensitivity Level rating according to the JEDEC industry standard classifications.

6 PIN CONFIGURATIONS

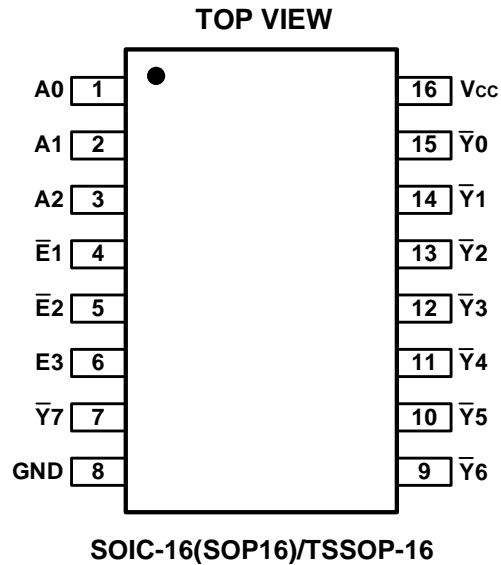

PIN DESCRIPTION

PIN	NAME	I/O TYPE ⁽¹⁾	FUNCTION
SOIC-16(SOP16)/TSSOP-16			
1	A0	I	Address input
2	A1	I	Address input
3	A2	I	Address input
4	$\bar{E}1$	I	Enable input (active LOW)
5	$\bar{E}2$	I	Enable input (active LOW)
6	E3	I	Enable input (active HIGH)
7	$\bar{Y}7$	O	Output
8	GND	-	Ground
9	$\bar{Y}6$	O	Output
10	$\bar{Y}5$	O	Output
11	$\bar{Y}4$	O	Output
12	$\bar{Y}3$	O	Output
13	$\bar{Y}2$	O	Output
14	$\bar{Y}1$	O	Output
15	$\bar{Y}0$	O	Output
16	Vcc	-	Power Supply

(1) I=Input, O=Output.

7 SPECIFICATIONS

7.1 Absolute Maximum Ratings ⁽¹⁾

over operating free-air temperature range (unless otherwise noted) ⁽¹⁾ ⁽²⁾

		MIN	MAX	UNIT
V _{CC}	Supply voltage range	-0.5	7	V
I _{IK}	Input clamp diode current	For V _I < 0.5V or V _I > V _{CC} + 0.5V		±20 mA
I _{OK}	Output clamp diode current	For V _O < -0.5V or V _O > V _{CC} + 0.5V		±20 mA
I _O	Output source or sink current per output pin	For V _O > -0.5V or V _O < V _{CC} + 0.5V		±25 mA
	Continuous current through V _{CC} or GND		±50	mA
θ _{JA}	Package thermal impedance ⁽³⁾	SOIC-16(SOP16)		150 °C/W
		TSSOP-16		45
T _J	Junction temperature ⁽⁴⁾	-65	150	°C
T _{stg}	Storage temperature	-65	150	°C
	Lead temperature (Soldering 10s) (SOIC - Lead Tips Only) 300 °C		300	°C

- (1) Stresses beyond those listed under *Absolute Maximum Ratings* may cause permanent damage to the device. These are stress ratings only, and functional operation of the device at these or any other conditions beyond those indicated under *Recommended Operating Conditions* is not implied. Exposure to absolute-maximum-rated conditions for extended periods may affect device reliability.
- (2) The input and output negative-voltage ratings may be exceeded if the input and output current ratings are observed.
- (3) The package thermal impedance is calculated in accordance with JESD-51.
- (4) The maximum power dissipation is a function of T_{J(MAX)}, R_{θJA}, and T_A. The maximum allowable power dissipation at any ambient temperature is P_D = (T_{J(MAX)} - T_A) / R_{θJA}. All numbers apply for packages soldered directly onto a PCB.

7.2 ESD Ratings

The following ESD information is provided for handling of ESD-sensitive devices in an ESD protected area only.

		VALUE	UNIT
V _(ESD) Electrostatic discharge	Human-body model (HBM), per ANSI/ESDA/JEDEC JS-001 ⁽¹⁾	±2000	V
	Charged-device model (CDM), per ANSI/ESDA/JEDEC JS-002 ⁽²⁾	±1000	V
	Machine model (MM)	±200	V

- (1) JEDEC document JEP155 states that 500 V HBM allows safe manufacturing with a standard ESD control process.
- (2) JEDEC document JEP157 states that 250 V CDM allows safe manufacturing with a standard ESD control process.



ESD SENSITIVITY CAUTION

ESD damage can range from subtle performance degradation to complete device failure. Precision integrated circuits may be more susceptible to damage because very small parametric changes could cause the device not to meet its published specifications.

7.3 Recommended Operating Conditions

PARAMETER	SYMBOL	TEST CONDITIONS	MIN	MAX	UNIT
Supply voltage	V_{CC}		4.5	5.5	V
Input voltage	V_I		0	V_{CC}	V
Output voltage	V_O		0	V_{CC}	V
Input rise and fall time	t_t	$V_{CC}=4.5V$		500	ns
		$V_{CC}=5.5V$		400	
Operating temperature	T_A		-40	125	°C

(1) All unused inputs of the device must be held at V_{CC} or GND to ensure proper device operation.

7.4 ELECTRICAL CHARACTERISTICS

PARAMETER	TEST CONDITIONS (4)	V_{CC}	Operating free-air temperature (T_A)									UNIT
			25°C			-40°C to 85°C			-40°C to 125°C			
			MIN (2)	TYP (3)	MAX (2)	MIN (2)	TYP (3)	MAX (2)	MIN (2)	TYP (3)	MAX (2)	
V_{IH}		4.5 to 5.5	2			2			2		V	
V_{IL}		4.5 to 5.5			0.8			0.8			0.8	V
V_{OH}	$I_{OH} = -20\mu A$	4.5	4.4			4.4			4.4		V	
	$I_{OH} = -4mA$	4.5	3.98			3.84			3.7			
V_{OL}	$I_{OL} = 20\mu A$	4.5			0.1			0.1			V	
	$I_{OL} = 4mA$	4.5			0.26			0.33				0.4
I_I	$V_I = V_{CC}$ or GND	5.5			± 0.1			± 1			± 1	μA
I_{CC}	$V_I = V_{CC}$ or GND	5.5			8			80			160	μA
ΔI_{CC}	A0 - A2 inputs held at $V_{CC} - 2.1V$	4.5 to 5.5	100	540			675			735	μA	
	$\bar{E}1$ and $\bar{E}2$ inputs held at $V_{CC} - 2.1V$	4.5 to 5.5	100	450			562.5			612.5	μA	
	E3 input held at $V_{CC} - 2.1V$	4.5 to 5.5	100	360			450			490	μA	

(1) All unused inputs of the device must be held at V_{CC} or GND to ensure proper device operation.

(2) Limits are 100% production tested at 25°C. Limits over the operating temperature range are ensured through correlations using statistical quality control (SQC) method.

(3) Typical values represent the most likely parametric norm as determined at the time of characterization. Actual typical values may vary over time and will also depend on the application and configuration.

(4) $V_I = V_{IH}$ or V_{IL} , unless otherwise noted.

7.5 Switching Characteristics

Input $t_i = 6\text{ns}$.

PARAMETER	TEST CONDITIONS	V_{CC}	Operating free-air temperature (T_A)									UNIT
			25°C			-40°C to 85°C			-40°C to 125°C			
			MIN (2)	TYP (3)	MAX (2)	MIN (2)	TYP (3)	MAX (2)	MIN (2)	TYP (3)	MAX (2)	
t_{pd}	Address to output	$C_L = 50\text{pF}$	4.5	12	15			16			17	ns
	Strobe E3 to output RS138T	$C_L = 50\text{pF}$	4.5		15			16			17	ns
	Strobe $\bar{E}1, \bar{E}2$ to output RS138T	$C_L = 15\text{pF}$	4.5		13			14			15	ns
t_t	Output transition time	$C_L = 15\text{pF}$	4.5		12			13			14	ns
C_{PD}	Power dissipation Capacitance ⁽⁴⁾	$C_L = 15\text{pF}$	5		67							pF
C_i	Input capacitance				10			10			10	pF

(1) All unused inputs of the device must be held at V_{CC} or GND to ensure proper device operation.

(2) This parameter is ensured by design and/or characterization and is not tested in production.

(3) Typical values represent the most likely parametric norm as determined at the time of characterization. Actual typical values may vary over time and will also depend on the application and configuration.

(4) C_{PD} is used to determine the dynamic power consumption, per gate.

8 Parameter Measurement Information

Phase relationships between waveforms were chosen arbitrarily. All input pulses are supplied by generators having the following characteristics: $PRR \leq 1 \text{ MHz}$, $Z_O = 50 \Omega$, $t_i < 6 \text{ ns}$.

For clock inputs, f_{max} is measured when the input duty cycle is 50%.

The outputs are measured one at a time with one input transition per measurement.

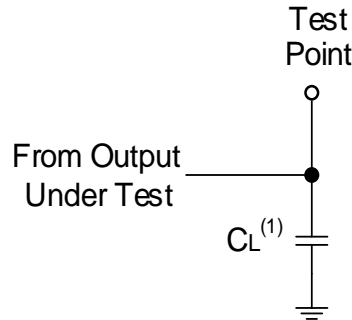

(1) C_L includes probe and test-fixture capacitance.

Figure 1. Load Circuit for Push-Pull Outputs

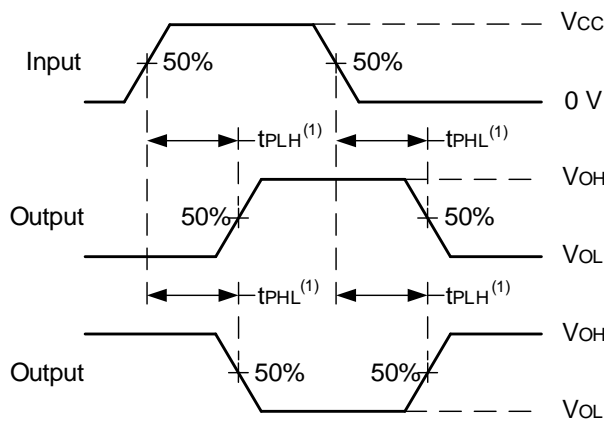

(1) The greater between t_{PLH} and t_{PHL} is the same as t_{pd} .

Figure 2. Voltage Waveforms, Propagation Delays for Standard CMOS Inputs

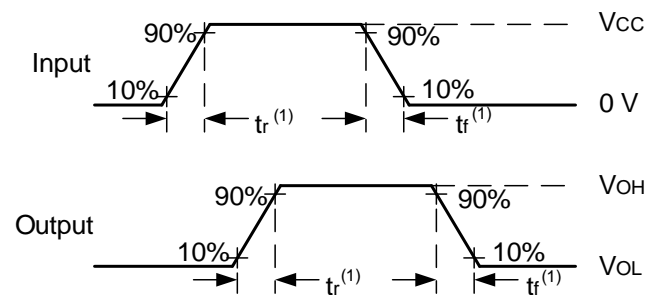

(1) The greater between t_r and t_f is the same as t_i .

Figure 3. Voltage Waveforms, Input and Output Transition Times for Standard CMOS Inputs

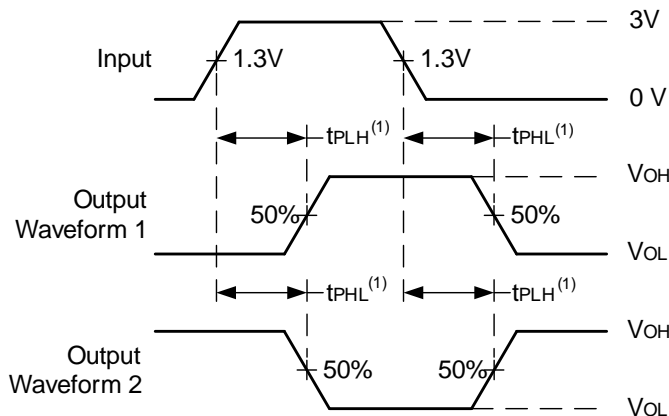

(1) The greater between t_{PLH} and t_{PHL} is the same as t_{pd} .

Figure 4. Voltage Waveforms, Propagation Delays for TTL-Compatible Inputs

9 Detailed Description

9.1 Overview

The RS138T device is 3-to-8 decoders/demultiplexers. The three address input pins, A0, A1, and A2, select which output is active. The selected output is pulled LOW, while the remaining outputs are all HIGH. The conditions at the binary weighted inputs at the three enable inputs select one of eight output lines. The three enable input pins, E3, $\bar{E}2$ and $\bar{E}1$. One active high enable and two active low enable pins are available, and any enable pin can be deactivated to force all outputs high. All three enable pins must be active for the output to be enabled.

9.2 Functional Block Diagram

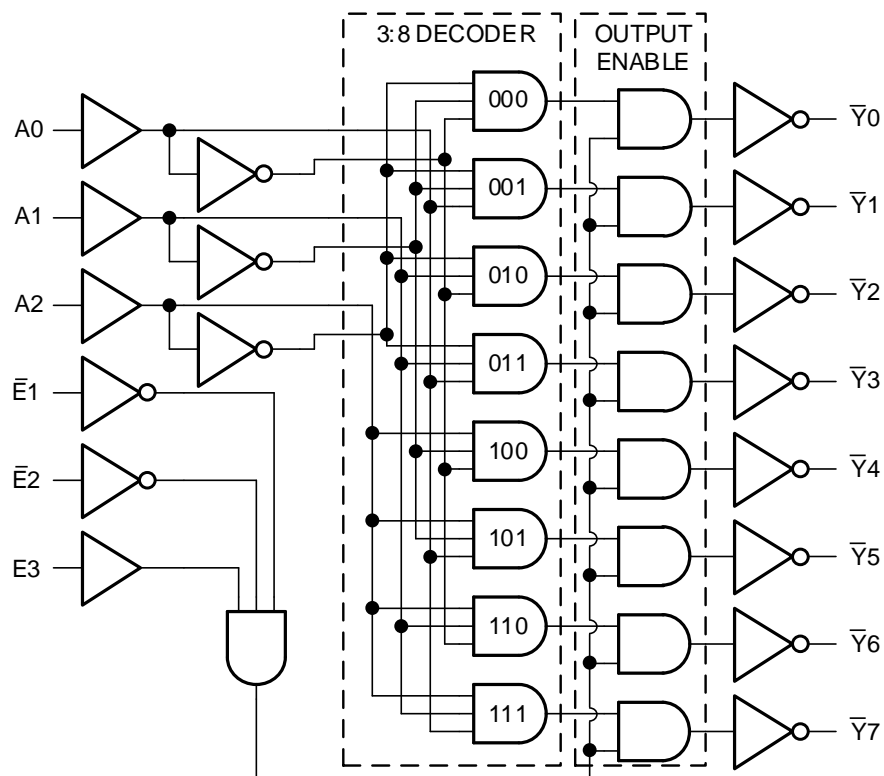

Figure 5. Functional Block Diagram

9.3 Device Functional Modes

Device Function Table

ENABLE INPUTS			ADDRESS INPUTS			OUTPUTS							
E3	$\bar{E}2$	$\bar{E}1$	A2	A1	A0	$\bar{Y}0$	$\bar{Y}1$	$\bar{Y}2$	$\bar{Y}3$	$\bar{Y}4$	$\bar{Y}5$	$\bar{Y}6$	$\bar{Y}7$
X	H	X	X	X	X	H	H	H	H	H	H	H	H
X	X	H	X	X	X	H	H	H	H	H	H	H	H
L	X	X	X	X	X	H	H	H	H	H	H	H	H
H	L	L	L	L	L	L	H	H	H	H	H	H	H
H	L	L	L	L	H	H	L	H	H	H	H	H	H
H	L	L	L	H	L	H	H	L	H	H	H	H	H
H	L	L	L	H	H	H	H	H	L	H	H	H	H
H	L	L	H	L	L	H	H	H	H	L	H	H	H
H	L	L	H	L	H	H	H	H	H	H	L	H	H
H	L	L	H	H	L	H	H	H	H	H	H	L	H
H	L	L	H	H	H	H	H	H	H	H	H	H	L

H: High Voltage Level

L: Low Voltage Level

X: Don't care

10 Power Supply Recommendations

The power supply pin should have a good bypass capacitor to prevent power disturbance. For devices with a single supply, a 0.1 μF capacitor is recommended and if there are multiple V_{CC} terminals then 0.01 μF or 0.022 μF capacitors are recommended for each power terminal. It is acceptable to parallel multiple bypass caps to reject different frequencies of noise. The 0.1 μF and 1 μF capacitors are commonly used in parallel. The bypass capacitor should be installed as close to the power terminal as possible.

11 Layout

11.1 Layout Guidelines

When using multiple bit logic devices inputs should not ever float. In many cases, functions or parts of functions of digital logic devices are unused; for example, when only two inputs of a triple-input AND gate are used or only 3 of the 4 buffer gates are used. Such input pins should not be left unconnected because the undefined voltages at the outside connections result in undefined operational states. Specified below are the rules that must be observed under all circumstances. All unused inputs of digital logic devices must be connected to a high or low bias to prevent them from floating. The logic level that should be applied to any particular unused input depends on the function of the device. Generally, they will be tied to GND or V_{CC} whichever make more sense or is more convenient.

11.2 Layout Example

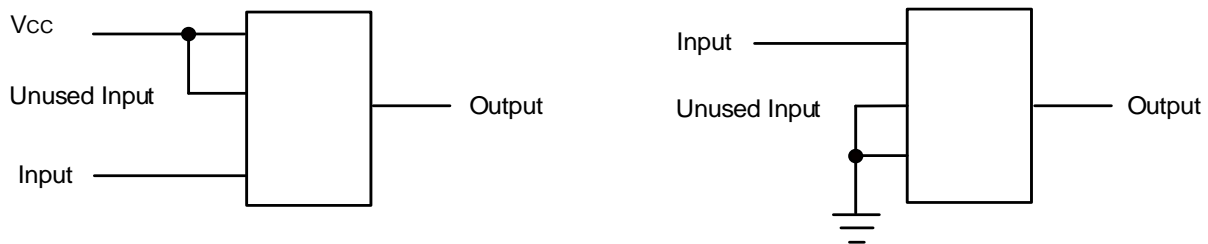
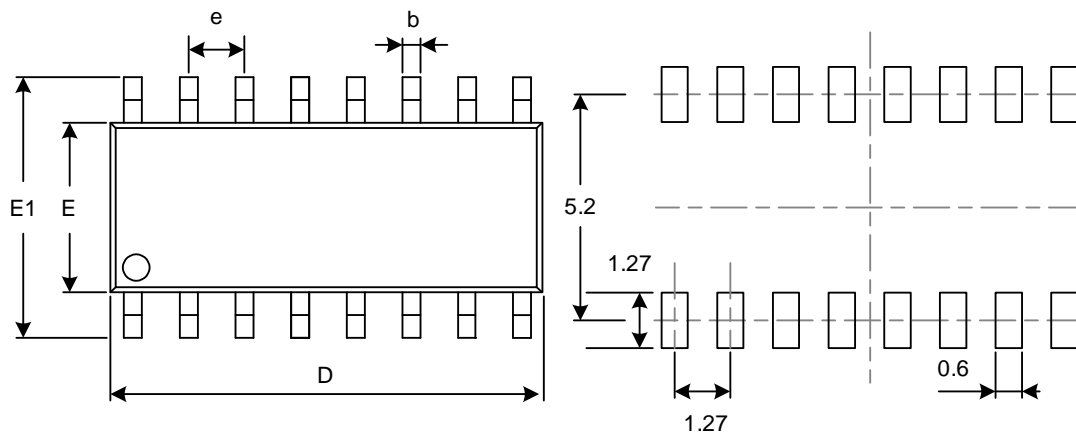
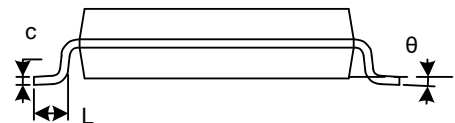
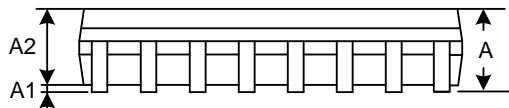
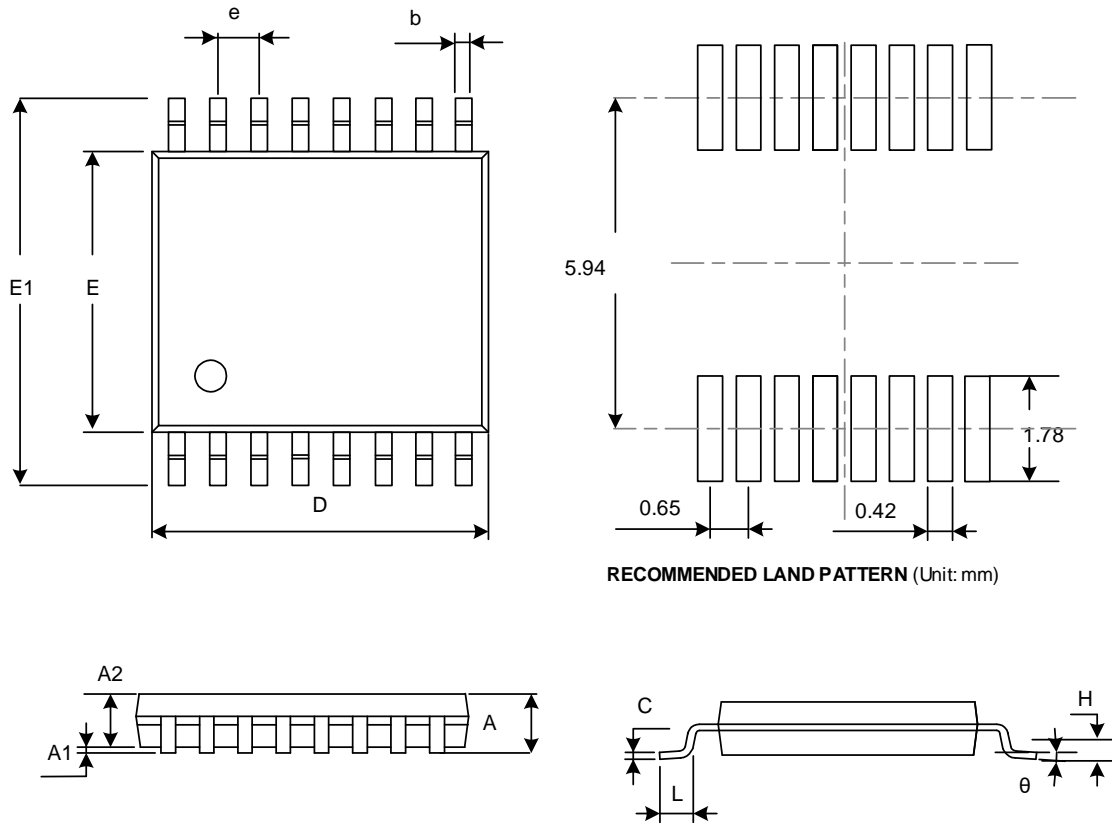

Figure 6. Layout Diagram

12 PACKAGE OUTLINE DIMENSIONS SOIC-16(SOP16)

RECOMMENDED LAND PATTERN (Unit:mm)

Symbol	Dimensions In Millimeters		Dimensions In Inches	
	Min	Max	Min	Max
A	1.350	1.750	0.053	0.069
A1	0.100	0.250	0.004	0.010
A2	1.350	1.550	0.053	0.061
b	0.330	0.510	0.013	0.020
c	0.170	0.250	0.006	0.010
D	9.800	10.200	0.386	0.402
E	3.800	4.000	0.150	0.157
E1	5.800	6.200	0.228	0.244
e	1.270(BSC)		0.050(BSC)	
L	0.400	1.270	0.016	0.050
θ	0°	8°	0°	8°

TSSOP-16

RECOMMENDED LAND PATTERN (Unit: mm)

Symbol	Dimensions In Millimeters		Dimensions In Inches	
	Min	Max	Min	Max
A		1.200		0.047
A1	0.050	0.150	0.002	0.006
A2	0.800	1.050	0.031	0.041
b	0.190	0.300	0.007	0.012
c	0.090	0.200	0.004	0.008
D	4.860	5.100	0.191	0.201
E	4.300	4.500	0.169	0.177
E1	6.200	6.600	0.244	0.260
e	0.650(BSC)		0.026(BSC)	
L	0.500	0.700	0.02	0.028
H	0.25TYP		0.01TYP	
θ	1°	7°	1°	7°

NOTE:

- A. All linear dimension is in millimeters.
- B. This drawing is subject to change without notice.
- C. Body dimensions do not include mold flash or protrusion. Mold flash and protrusion shall not exceed 0.15 per side.
- D. BSC: Basic Dimension. Theoretically exact value shown without tolerances.

13 TAPE AND REEL INFORMATION REEL DIMENSIONS

TAPE DIMENSION

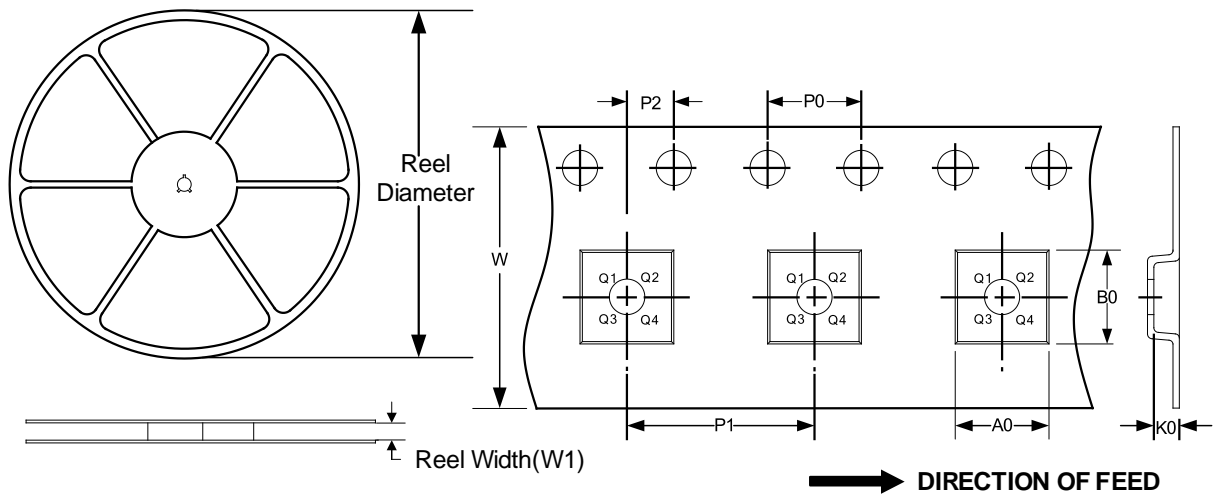

NOTE: The picture is only for reference. Please make the object as the standard.

KEY PARAMETER LIST OF TAPE AND REEL

Package Type	Reel Diameter	Reel Width(mm)	A0 (mm)	B0 (mm)	K0 (mm)	P0 (mm)	P1 (mm)	P2 (mm)	W (mm)	Pin1 Quadrant
SOIC-16(SOP16)	13"	16.4	6.50	10.30	2.10	4.0	8.0	2.0	16.0	Q1
TSSOP-16	13"	12.4	6.90	5.60	1.20	4.0	8.0	2.0	12.0	Q1

NOTE:

1. All dimensions are nominal.
2. Plastic or metal protrusions of 0.15mm maximum per side are not included.

IMPORTANT NOTICE AND DISCLAIMER

Jiangsu Runic Technology Co., Ltd. will accurately and reliably provide technical and reliability data (including data sheets), design resources (including reference designs), application or other design advice, WEB tools, safety information and other resources, without warranty of any defect, and will not make any express or implied warranty, including but not limited to the warranty of merchantability Implied warranty that it is suitable for a specific purpose or does not infringe the intellectual property rights of any third party.

These resources are intended for skilled developers designing with Runic products You will be solely responsible for: (1) Selecting the appropriate products for your application; (2) Designing, validating and testing your application; (3) Ensuring your application meets applicable standards and any other safety, security or other requirements; (4) Runic and the Runic logo are registered trademarks of Runic Incorporated. All trademarks are the property of their respective owners; (5) For change details, review the revision history included in any revised document. The resources are subject to change without notice. Our company will not be liable for the use of this product and the infringement of patents or third-party intellectual property rights due to its use.