



LR1142

CMOS IC

HIGH PSRR, LOW DROPOUT, 500mA ADJUSTABLE LDO REGULATOR

DESCRIPTION

The UTC **LR1142** is a CMOS-based 500mA voltage regulator with low supply current, low dropout, adjustable output voltage, The device offering high PSRR and low dropout. The quiescent current is as low as 35µA, further prolonging the battery life. The UTC **LR1142** also works with low-ESR ceramic capacitors, reducing the amount of board space necessary for power applications, critical in handheld wireless devices.

The UTC **LR1142** consumes typical 0.7µA in shutdown mode. The other features include low dropout voltage, high output accuracy, current limit protection, and enable/shutdown control.

FEATURES

- * Wide operating voltage range: 2.5V~5.5V
- * Adjustable output voltage
- * Enable/shutdown control
- * Low-noise for RF application
- * Ultra-Fast response in line/load transient
- * Current limit protection
- * Output only 1µF capacitor required for stability
- * High power supply rejection ratio

ORDERING INFORMATION

Ordering Number		Package	Packing
Lead Free	Halogen Free		
LR1142L-xx-AE5-A-R	LR1142G-xx-AE5-A-R	SOT-23-5	Tape Reel
LR1142L-xx-AE5-B-R	LR1142G-xx-AE5-B-R	SOT-23-5	Tape Reel
LR1142L-xx-AF5-A-R	LR1142G-xx-AF5-A-R	SOT-25	Tape Reel
LR1142L-xx-AF5-B-R	LR1142G-xx-AF5-B-R	SOT-25	Tape Reel
LR1142L-xx-K06-1616-R	LR1142G-xx-K06-1616-R	DFN1616-6	Tape Reel
LR1142L-xx-K06-2020-R	LR1142G-xx-K06-2020-R	DFN2020-6	Tape Reel

Note: xx: Output Voltage, refer to Marking Information.

<p>LR1142G-xx-AE5-A-R</p>	<p>(1) R: Tape Reel (2) refer to PIN CONFIGURATION (3) AE5: SOT-23-5, AF5: SOT-25, K06-1616: DFN1616-6, K06-2020: DFN2020-6 (4) xx: refer to Marking Information (5) G: Halogen Free and Lead Free, L: Lead Free</p>
---------------------------	---

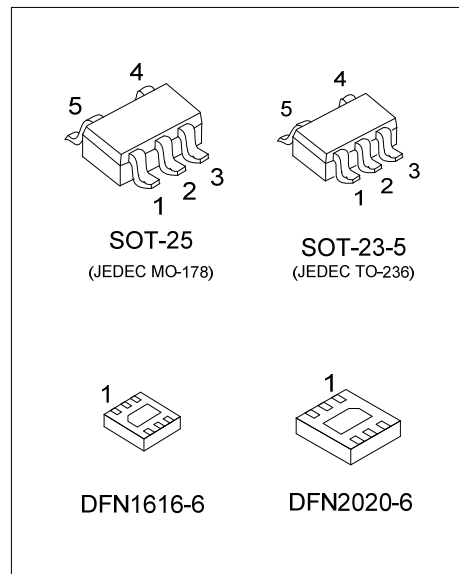

MARKING INFORMATION

PACKAGE	VOLTAGE CODE	MARKING
SOT-23-5 SOT-25	AD: ADJ	
DFN1616-6 DFN2020-6		

PIN CONFIGURATION

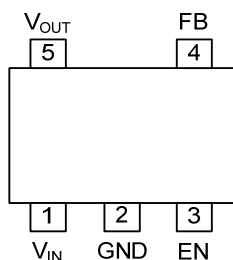

LR1142-A
SOT-23-5 / SOT-25

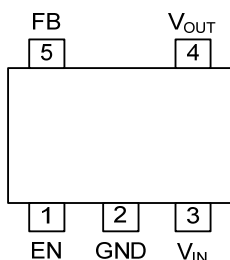

LR1142-B
SOT-23-5 / SOT-25

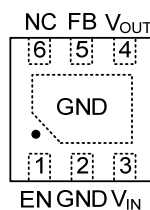

DFN1616-6
(TOP VIEW)

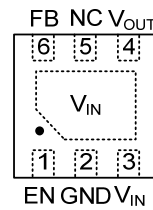

DFN2020-6
(TOP VIEW)

PIN DESCRIPTION

PIN NO.				PIN NAME	DESCRIPTION
SOT-23-5 / SOT-25		DFN1616-6	DFN2020-6		
LR1142-A	LR1142-B				
1	3	3	3	V _{IN}	Voltage Input.
2	2	2	2	GND	Ground.
3	1	1	1	EN	Chip Enable (Active High).
4	5	5	6	FB	Output Voltage Feedback.
5	4	4	4	V _{OUT}	Voltage Output.
-	-	6	5	NC	No Connection
-	-	Exposed Pad	-	GND	Ground.
-	-	-	Exposed Pad	V _{IN}	Connect exposed pad to V _{IN} .

■ BLOCK DIAGRAM

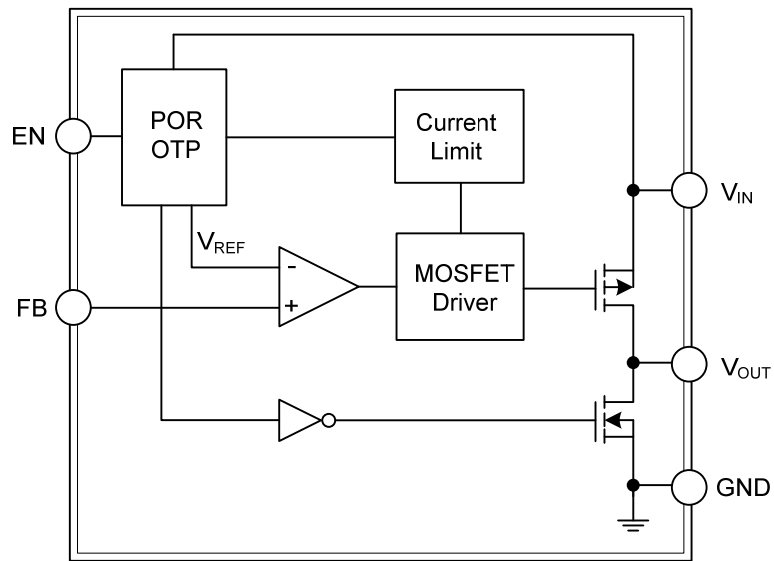

■ ABSOLUTE MAXIMUM RATING

PARAMETER		SYMBOL	RATINGS	UNIT
Supply Input Voltage		V_{IN}	6	V
EN Input Voltage		V_{EN}	6	V
Power Dissipation ($T_A=25^\circ\text{C}$)	SOT-23-5	P_D	0.4	W
	SOT-25			
	DFN1616-6		780 (Note 2)	mW
	DFN2020-6		950 (Note 2)	mW
Junction Temperature		T_J	+150	$^\circ\text{C}$
Storage Temperature		T_{STG}	-65 ~ +150	$^\circ\text{C}$

Notes: 1. Absolute maximum ratings are those values beyond which the device could be permanently damaged.

Absolute maximum ratings are stress ratings only and functional device operation is not implied.

2. The data tested by surface mounted on a 2 inch² FR-4 board with 2OZ copper.

■ RECOMMENDED OPERATING CONDITIONS

PARAMETER	SYMBOL	MIN	TYP	MAX	UNIT
Ambient Temperature Range	T_A	-40		+85	$^\circ\text{C}$

Note: The device is not guaranteed to function outside its operating conditions.

■ THERMAL DATA

PARAMETER		SYMBOL	RATINGS	UNIT
Junction to Ambient	SOT-23-5	θ_{JA}	280	$^\circ\text{C/W}$
	SOT-25			
	DFN1616-6		160 (Note)	$^\circ\text{C/W}$
	DFN2020-6		131 (Note)	$^\circ\text{C/W}$
Case to Ambient	SOT-23-5	θ_{JC}	90	$^\circ\text{C/W}$
	SOT-25			
	DFN1616-6		32	$^\circ\text{C/W}$
	DFN2020-6		28	$^\circ\text{C/W}$

Note: The data tested by surface mounted on a 2 inch² FR-4 board with 2OZ copper.

■ ELECTRICAL CHARACTERISTICS

($V_{IN}=V_{OUT}+1\text{V}$, $T_A=25^\circ\text{C}$, $C_{IN}=C_{OUT}=1\mu\text{F}$, $I_{OUT}=20\text{mA}$, unless otherwise specified)

PARAMETER		SYMBOL	TEST CONDITIONS	MIN	TYP	MAX	UNIT
Input Voltage Range		V_{IN}		2.5		5.5	V
Reference Voltage		V_{REF}		0.784	0.8	0.816	V
Quiescent Current		I_Q	$I_{OUT}=0\text{mA}$		35	70	μA
Shutdown Current		I_{SHDN}	$V_{EN}=0\text{V}$		0.7	1.5	μA
Current Limit		I_{LIM}		500	750		mA
Dropout Voltage		V_{DROP}	$V_{OUT}=3.3\text{V}$, $I_{OUT}=500\text{mA}$		370		mV
Load Regulation		ΔV_{LOAD}	$1\text{mA}<I_{OUT}<500\text{mA}$, $2.5\text{V}\leq V_{IN}<5.5\text{V}$			1	%
Line Regulation		ΔV_{LINE}	$V_{IN}=(V_{OUT}+0.5\text{V})\sim 5.5\text{V}$, $I_{OUT}=1\text{mA}$		0.01	0.2	%/V
EN Threshold	Logic-Low Voltage	V_{IL}		0		0.6	V
	Logic-High Voltage	V_{IH}		1.6		5.5	V
EN Pin Current		I_{EN}			0.1	1	μA
FB Pin Current		I_{FB}			0.1	1	μA
Power Supply Rejection Ratio		PSRR	$f=1\text{kHz}$, $I_{OUT}=10\text{mA}$		57		dB
			$f=10\text{kHz}$, $I_{OUT}=10\text{mA}$		40		dB
Output Noise Voltage		V_{ON}	$V_{OUT}=1.5\text{V}$, $C_{OUT}=1\mu\text{F}$, $I_{OUT}=0\text{mA}$		30		μVRMS

■ TYPICAL APPLICATION CIRCUIT

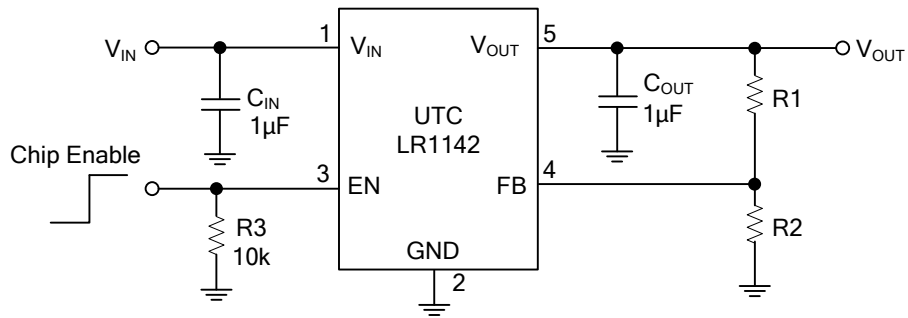

$$V_{OUT} = V_{REF} \left(1 + \frac{R_1}{R_2}\right)$$

TYPICAL CHARACTERISTICS

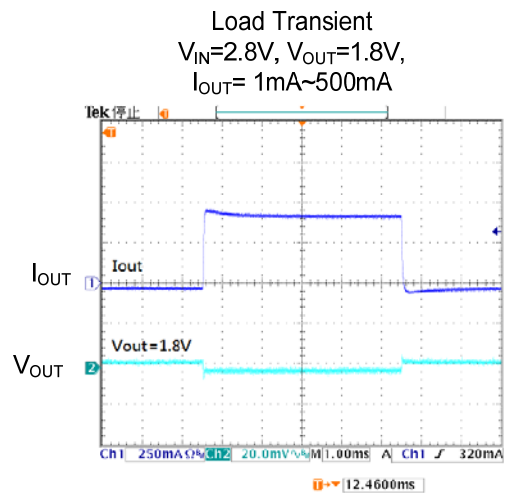
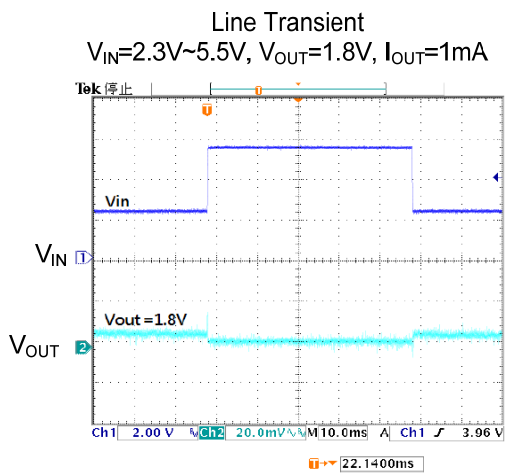
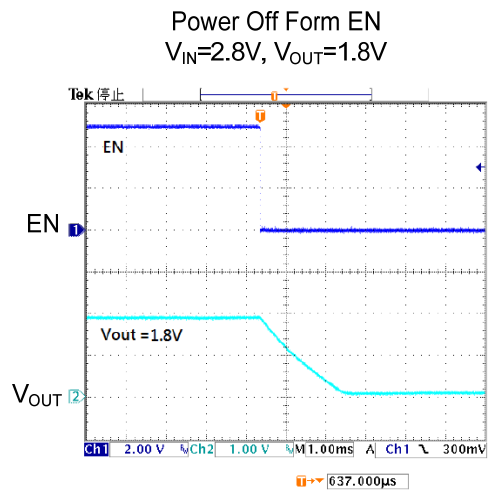
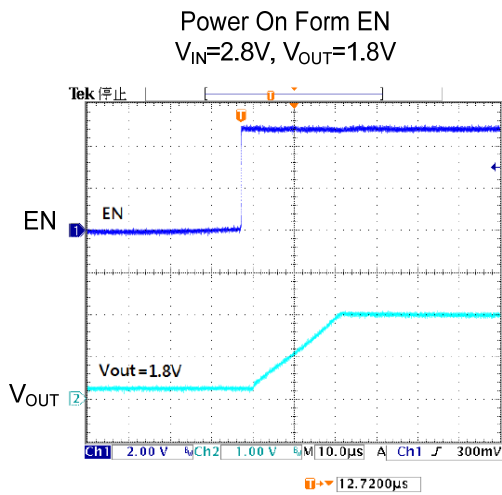
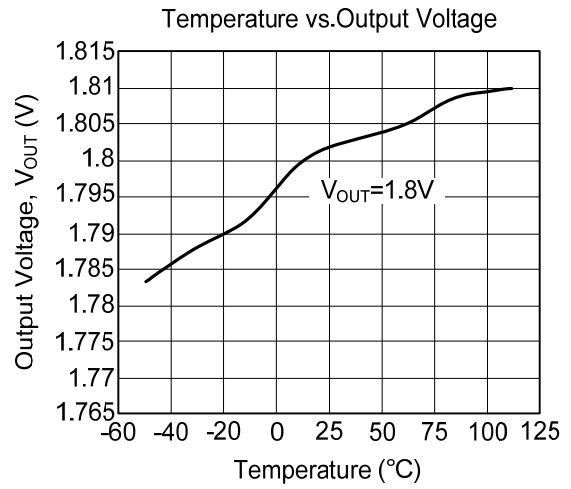
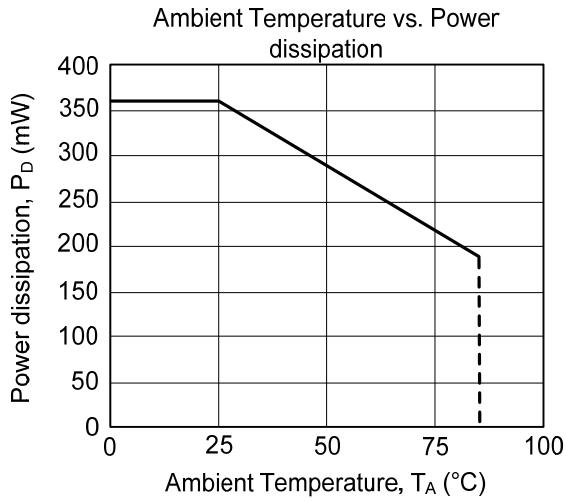

UTC assumes no responsibility for equipment failures that result from using products at values that exceed, even momentarily, rated values (such as maximum ratings, operating condition ranges, or other parameters) listed in products specifications of any and all UTC products described or contained herein. UTC products are not designed for use in life support appliances, devices or systems where malfunction of these products can be reasonably expected to result in personal injury. Reproduction in whole or in part is prohibited without the prior written consent of the copyright owner. UTC reserves the right to make changes to information published in this document, including without limitation specifications and product descriptions, at any time and without notice. This document supersedes and replaces all information supplied prior to the publication hereof.