



**135V 4.3mΩ N-Ch Power MOSFET**

**Features**

- Ultra-low  $R_{DS(ON)}$
- Low Gate Charge
- 100% UIS Tested, 100%  $R_g$  Tested
- Pb-free Lead Plating
- Halogen-free and RoHS-compliant

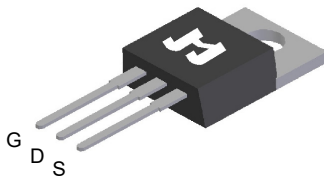
**Product Summary**

Parameter	Value	Unit
$V_{DS}$	135	V
$V_{GS(th\_Typ)}$	3.0	V
$I_D$ (@ $V_{GS} = 10V$ ) <sup>(1)</sup>	147	A
$R_{DS(ON)\_Typ}$ (@ $V_{GS} = 10V$ )	4.3	mΩ

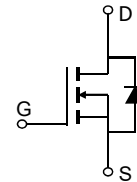
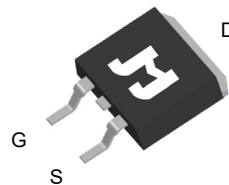
**Applications**

- Power Management in Telecom., Industrial Automation, CE
- Current Switching in DC/DC & AC/DC (SR) Sub-systems
- Motor Driving in Power Tool, E-vehicle, Robotics

TO-220-3L Top View



TO-263-3L Top View

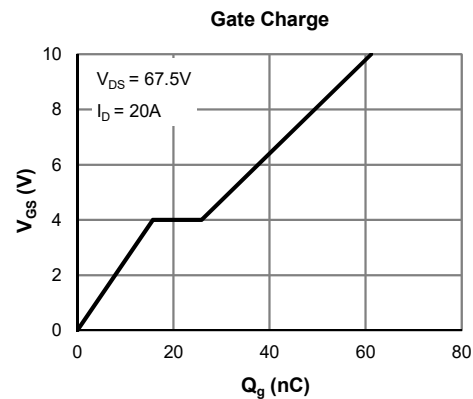
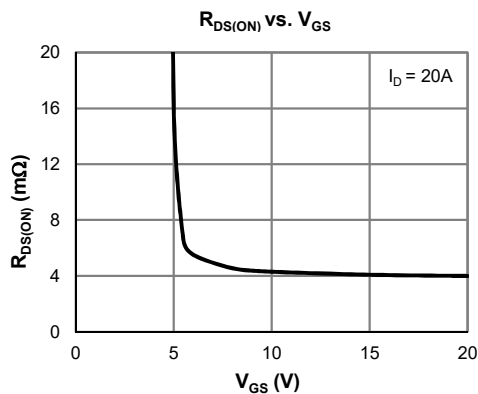


**Ordering Information**

Device	Package	# of Pins	Marking	MSL	$T_J$ (°C)	Media	Quantity (pcs)
JMSH1305AC-U	TO-220-3L	3	SH1305A	N/A	-55 to 150	Tube	50
JMSH1305AE-13	TO-263-3L	3	SH1305A	1	-55 to 150	13-inch Reel	800

**Absolute Maximum Ratings** (@  $T_A = 25^\circ C$  unless otherwise specified)

Parameter	Symbol	Value	Unit
Drain-to-Source Voltage	$V_{DS}$	135	V
Gate-to-Source Voltage	$V_{GS}$	±20	V
Continuous Drain Current <sup>(1)</sup>	$I_D$	$T_C = 25^\circ C$	147
		$T_C = 100^\circ C$	93
Pulsed Drain Current <sup>(2)</sup>	$I_{DM}$	588	A
Avalanche Current <sup>(3)</sup>	$I_{AS}$	60	A
Avalanche Energy <sup>(3)</sup>	$E_{AS}$	540	mJ
Power Dissipation <sup>(4)</sup>	$P_D$	$T_C = 25^\circ C$	236
		$T_C = 100^\circ C$	94
Junction & Storage Temperature Range	$T_J, T_{STG}$	-55 to 150	°C





**Electrical Characteristics** (@  $T_J = 25^\circ\text{C}$  unless otherwise specified)

Parameter	Symbol	Conditions	Min.	Typ.	Max.	Unit
<b>STATIC PARAMETERS</b>						
Drain-Source Breakdown Voltage	$V_{(BR)DSS}$	$I_D = 250\mu\text{A}, V_{GS} = 0\text{V}$	135			V
Zero Gate Voltage Drain Current	$I_{DSS}$	$V_{DS} = 108\text{V}, V_{GS} = 0\text{V}$			1.0	$\mu\text{A}$
					5.0	
Gate-Body Leakage Current	$I_{GSS}$	$V_{DS} = 0\text{V}, V_{GS} = \pm 20\text{V}$			$\pm 100$	nA
Gate Threshold Voltage	$V_{GS(th)}$	$V_{DS} = V_{GS}, I_D = 250\mu\text{A}$	2.0	3.0	4.0	V
Static Drain-Source ON-Resistance	$R_{DS(ON)}$	$V_{GS} = 10\text{V}, I_D = 20\text{A}$		4.3	5.0	m $\Omega$
Forward Transconductance	$g_{FS}$	$V_{DS} = 5\text{V}, I_D = 20\text{A}$		64		S
Diode Forward Voltage	$V_{SD}$	$I_S = 1\text{A}, V_{GS} = 0\text{V}$		0.71	1.0	V
Diode Continuous Current	$I_S$	$T_C = 25^\circ\text{C}$			236	A

**DYNAMIC PARAMETERS** <sup>(5)</sup>

Input Capacitance	$C_{iss}$	$V_{GS} = 0\text{V}, V_{DS} = 67.5\text{V}, f = 1\text{MHz}$		4307		pF
Output Capacitance	$C_{oss}$			611		pF
Reverse Transfer Capacitance	$C_{rss}$			4.2		pF
Gate Resistance	$R_g$	$V_{GS} = 0\text{V}, V_{DS} = 0\text{V}, f = 1\text{MHz}$		1.9		$\Omega$

**SWITCHING PARAMETERS** <sup>(5)</sup>

Total Gate Charge (@ $V_{GS} = 10\text{V}$ )	$Q_g$	$V_{GS} = 0 \text{ to } 10\text{V}$ $V_{DS} = 67.5\text{V}, I_D = 20\text{A}$		61		nC
Total Gate Charge (@ $V_{GS} = 6.0\text{V}$ )	$Q_g$			38		nC
Gate Source Charge	$Q_{gs}$			15.7		nC
Gate Drain Charge	$Q_{gd}$			10.1		nC
Turn-On Delay Time	$t_{D(on)}$	$V_{GS} = 10\text{V}, V_{DS} = 67.5\text{V}$ $R_L = 3.35\Omega, R_{GEN} = 6\Omega$		20		ns
Turn-On Rise Time	$t_r$			34		ns
Turn-Off Delay Time	$t_{D(off)}$			56		ns
Turn-Off Fall Time	$t_f$			40		ns
Body Diode Reverse Recovery Time	$t_{rr}$		$I_F = 15\text{A}, di_F/dt = 100\text{A}/\mu\text{s}$		93	
Body Diode Reverse Recovery Charge	$Q_{rr}$	$I_F = 15\text{A}, di_F/dt = 100\text{A}/\mu\text{s}$		133		nC

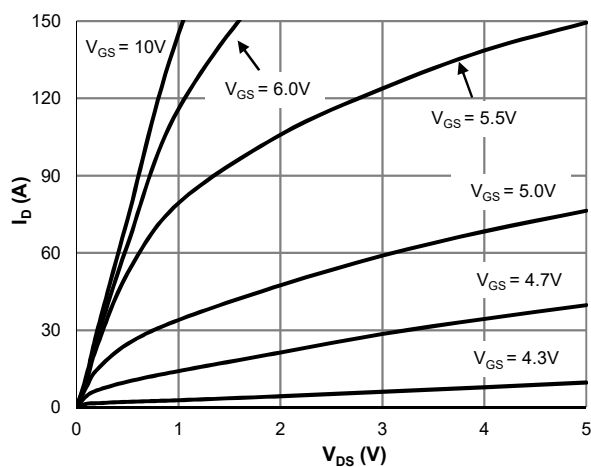
**Thermal Performance**

Parameter	Symbol	Typ.	Max.	Unit
Thermal Resistance, Junction-to-Ambient	$R_{\theta JA}$	50	60	$^\circ\text{C}/\text{W}$
Thermal Resistance, Junction-to-Case	$R_{\theta JC}$	0.44	0.53	$^\circ\text{C}/\text{W}$

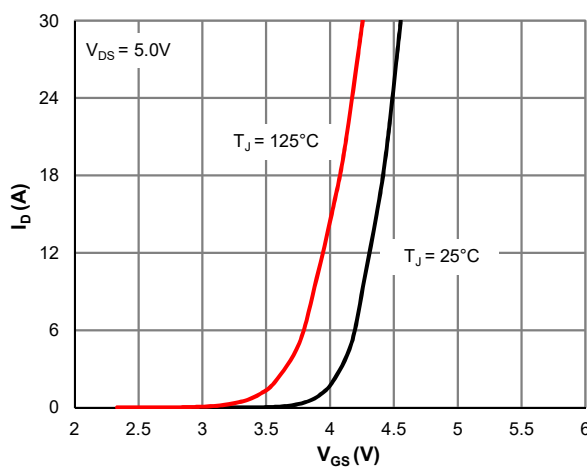
**Notes:**

1. Computed continuous current assumes the condition of  $T_{J\_Max}$  while the actual continuous current depends on the thermal & electro-mechanical application board design.
2. This single-pulse measurement was taken under  $T_{J\_Max} = 150^\circ\text{C}$ .
3. This single-pulse measurement was taken under the following condition [ $L = 300\mu\text{H}, V_{GS} = 10\text{V}, V_{DS} = 67.5\text{V}$ ] while its value is limited by  $T_{J\_Max} = 150^\circ\text{C}$ .
4. The power dissipation  $P_D$  is based on  $T_{J\_Max} = 150^\circ\text{C}$ .
5. This value is guaranteed by design hence it is not included in the production test.

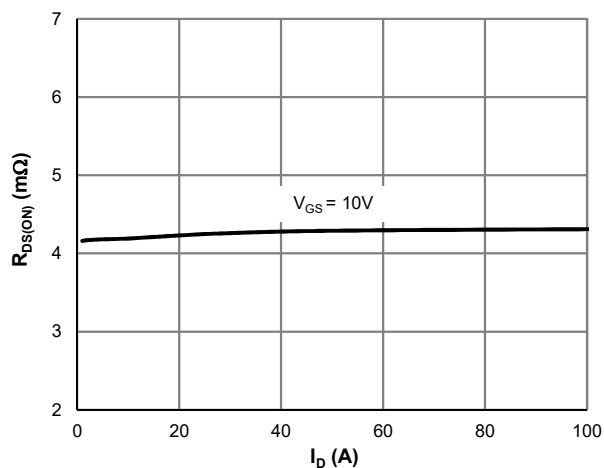
**Typical Electrical & Thermal Characteristics**



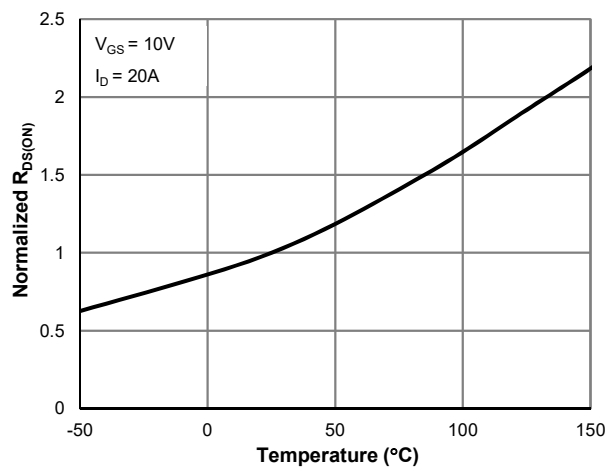
**Figure 1: Saturation Characteristics**



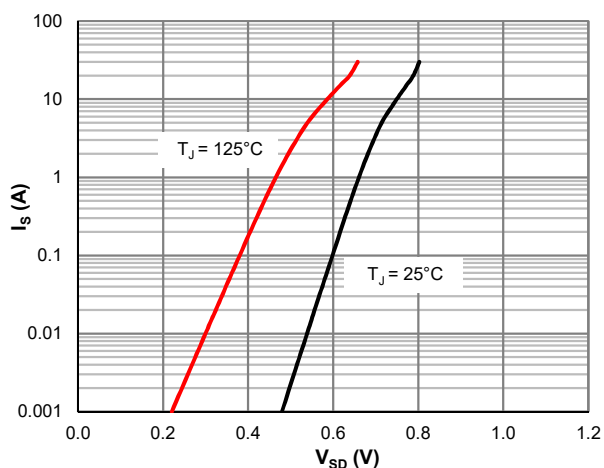
**Figure 2: Transfer Characteristics**



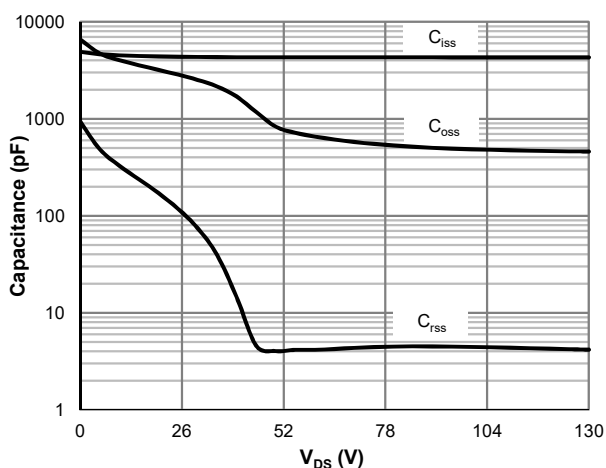
**Figure 3:  $R_{DS(ON)}$  vs. Drain Current**



**Figure 4:  $R_{DS(ON)}$  vs. Junction Temperature**

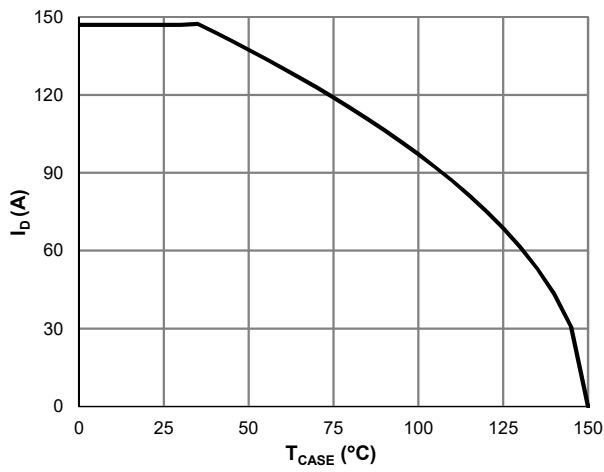


**Figure 5: Body-Diode Characteristics**

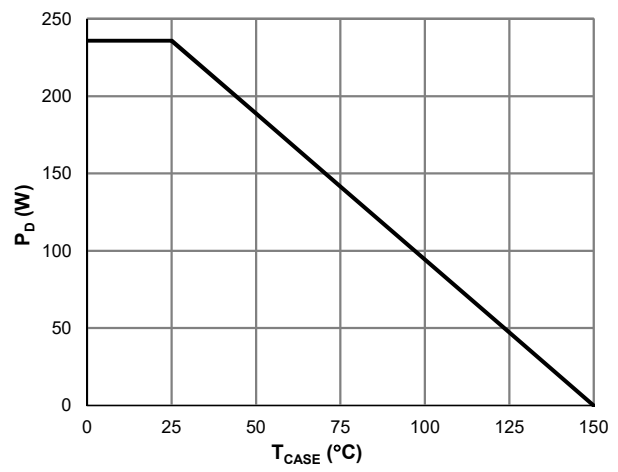


**Figure 6: Capacitance Characteristics**

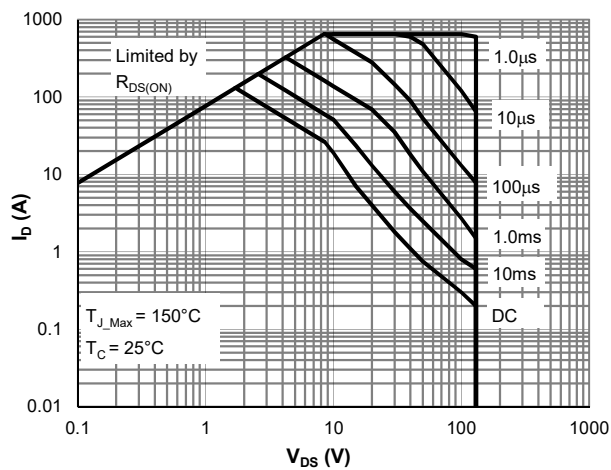
**Typical Electrical & Thermal Characteristics**



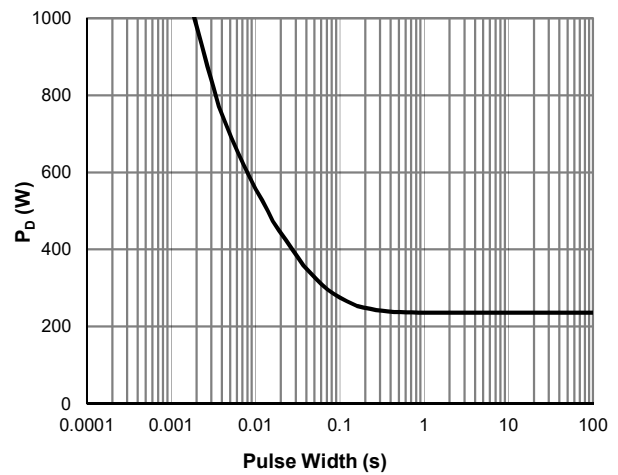
**Figure 7: Current De-rating**



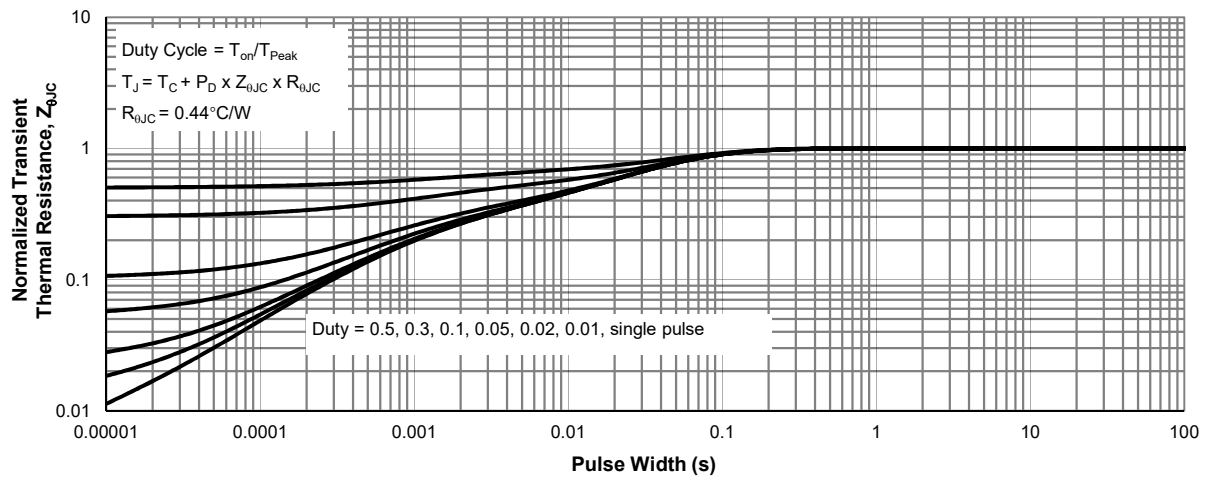
**Figure 8: Power De-rating**



**Figure 9: Maximum Safe Operating Area**



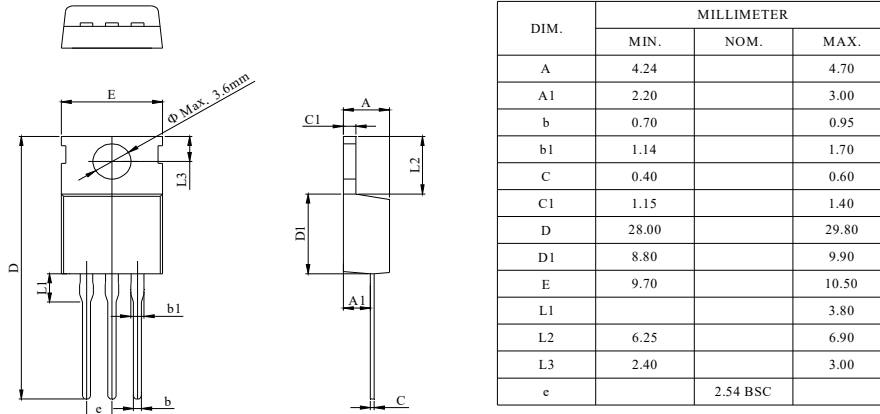
**Figure 10: Single Pulse Power Rating, Junction-to-Case**



**Figure 11: Normalized Maximum Transient Thermal Impedance**

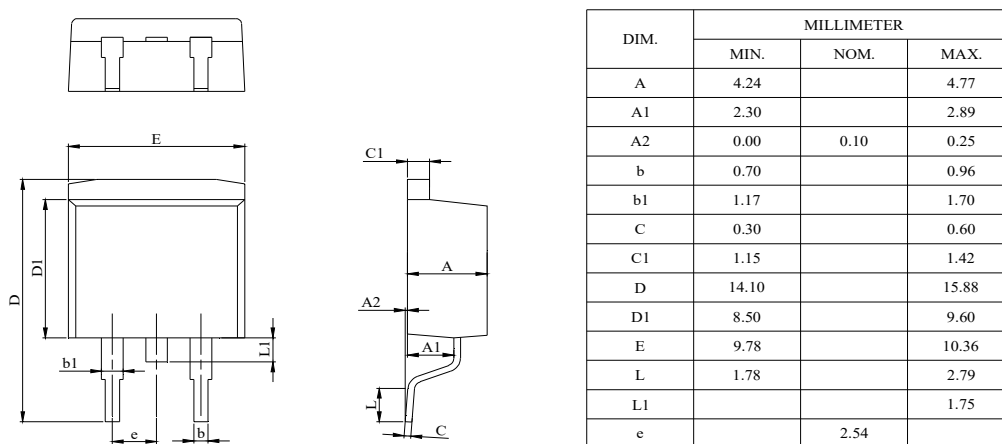
**TO-220-3L Package Information**

**Package Outline**



**TO-263-3L Package Information**

**Package Outline**



**Recommended Footprint**

